

Search for axion dark matter with high-frequency microwaves

Akira Miyazaki

CNRS/IN2P3/IJCLab Université Paris-Saclay



Who am I?



Prof. Koshiro Takahashi
Nobel Prize 2020
"Neutrino from SN1987"



Prof. Orito



Prof. Totsuka



Prof. Asai
KEK DG 2024-



SUSY
Guru

PhD supervisor



Prof. Kajita
Nobel Prize 2015
"Neutrino oscillation 1998"



PhD Thesis opponent



*Microwaves for
fundamental physics*

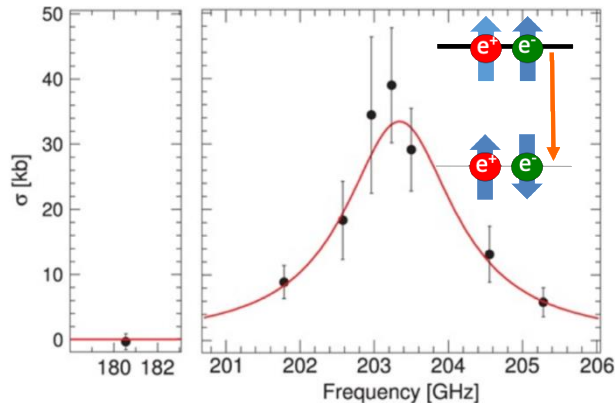

My vision in superconducting RF accelerators

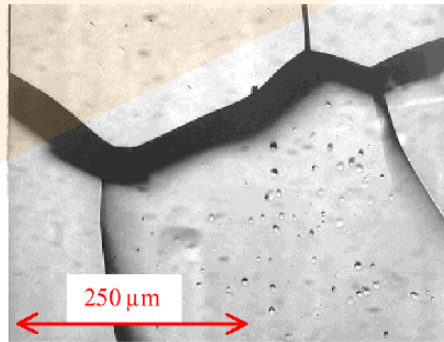
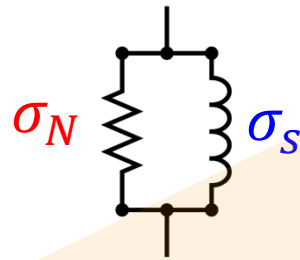
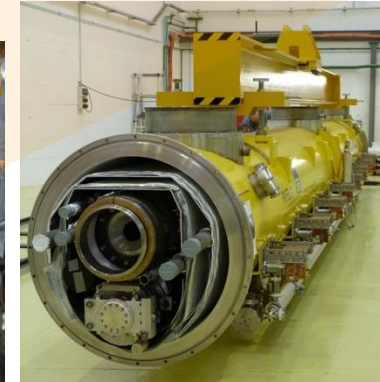
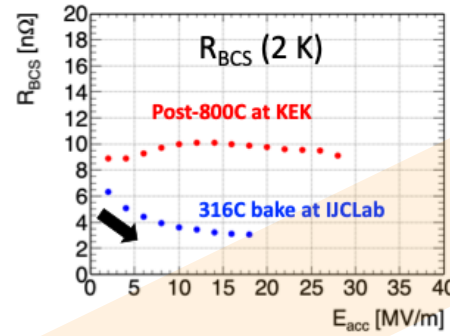
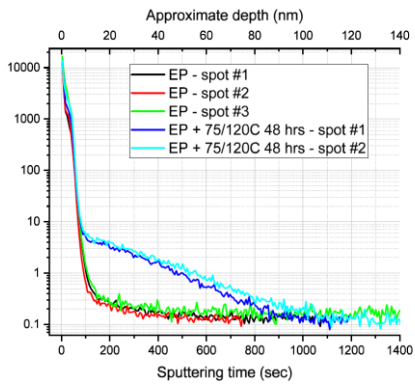
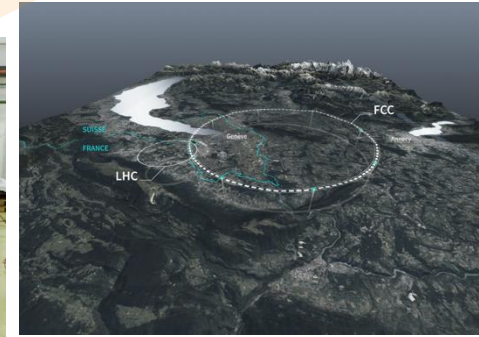
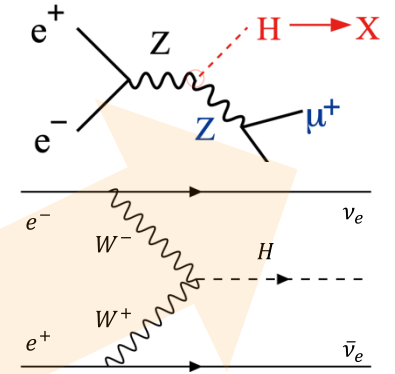
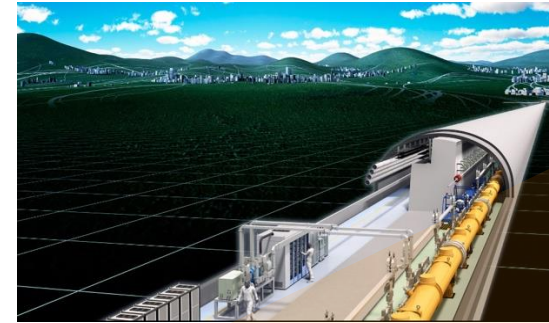
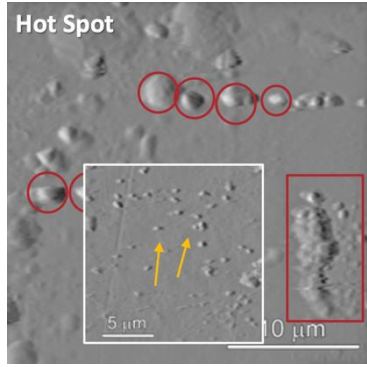

$$M \frac{\partial^2 \mathbf{u}}{\partial t^2} + \eta \frac{\partial \mathbf{u}}{\partial t} - \epsilon \frac{\partial^2 \mathbf{u}}{\partial z^2} + \nabla U(z, u) = \mathbf{J}_{RF}(z, u) \times \mathbf{B}_{ext}$$

From superconductivity
to particle physics
through huge MW &
cryogenic infrastructure

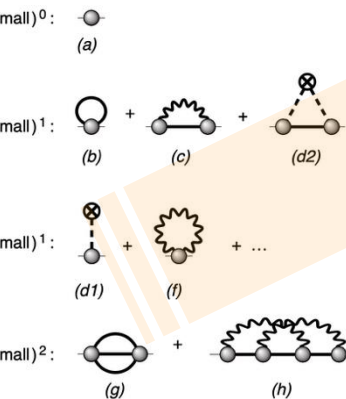

My main business: **Radio Frequency** cavities for accelerators

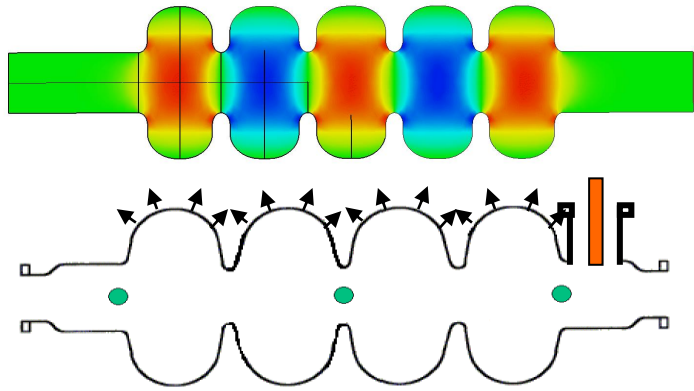

Courtesy: F. Bouly

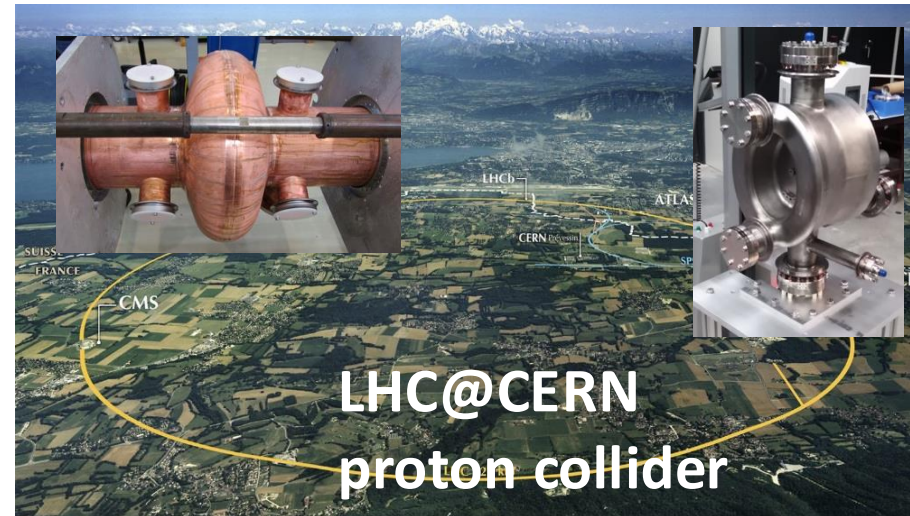

LHC@CERN
proton collider

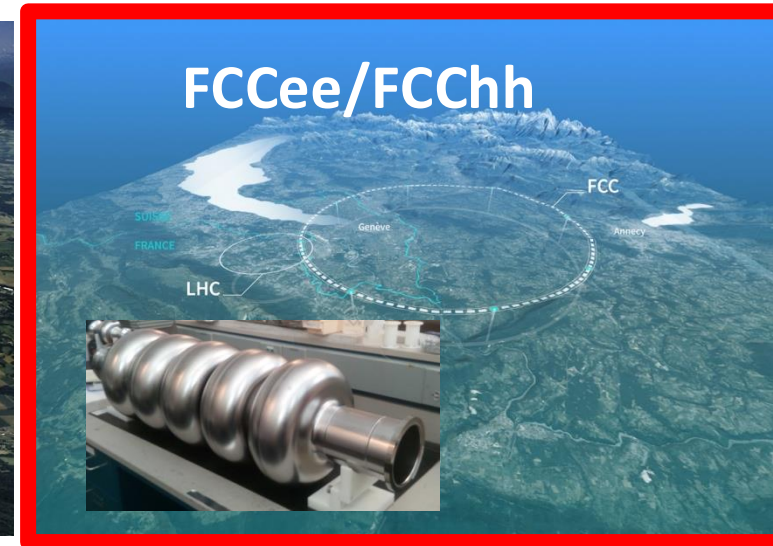

FCCee/FCChh



ESS@Lund
Proton Linac for neutrons

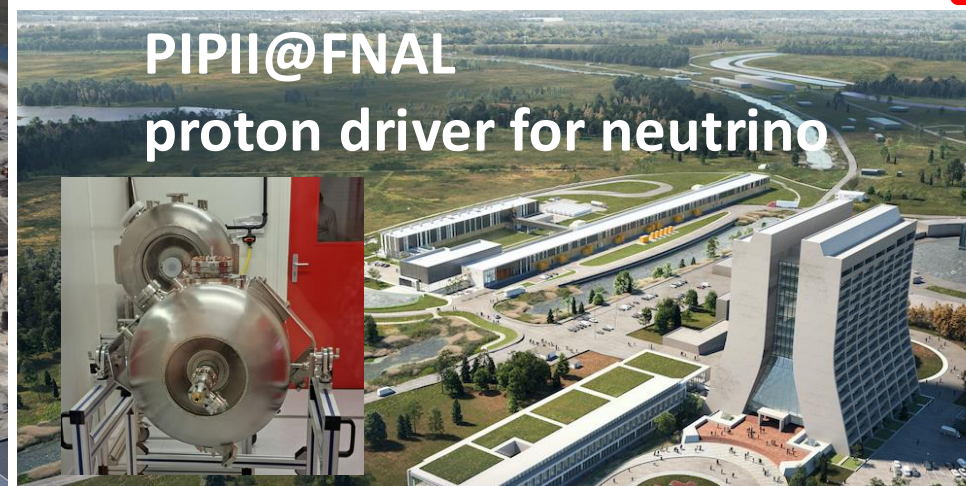

PIP-II@FNAL
proton driver for neutrino



ILC / LC facility

It will take time, very expensive, and very political ☹️

→ Can't we directly make use of **RF** for discovery?

Microwave photons may address fundamental physics

Axions

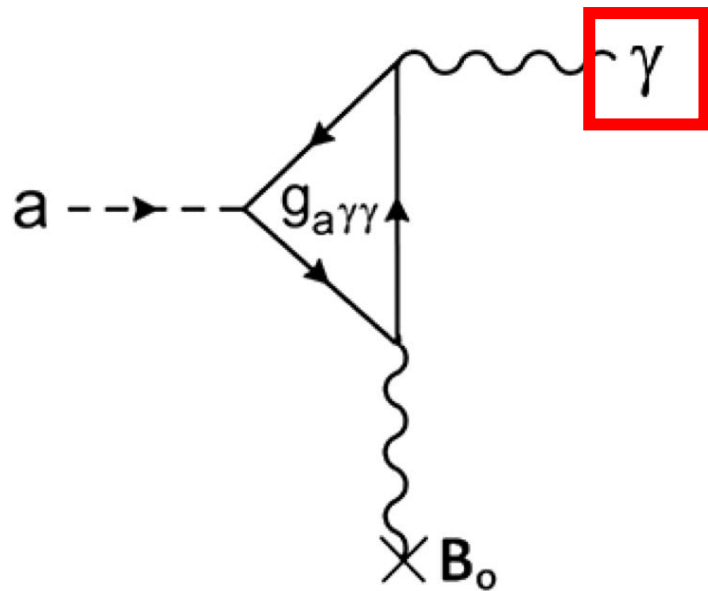

Inverse Primakoff effect

Minimal extension of SM

Neutrinos

$SU(2)_R \times U(1)$ theory are given in the graphs of fig. 2 also involving kinematic cases of interest; this case gives the standard model; this case describes the

Cosmic neutrino background

Extension of SM and/or SM

Gravitational waves

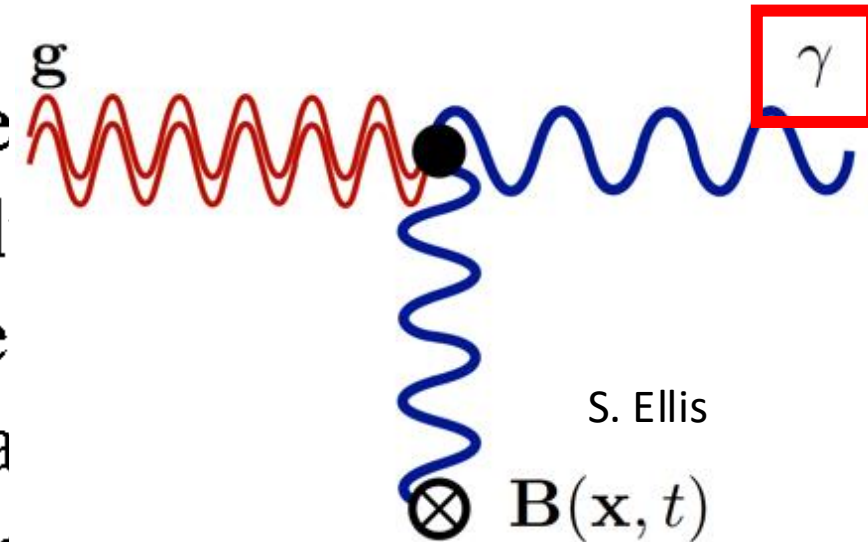

Inverse Gertsenshtein effect

Solution of general relativity

Shortcut!

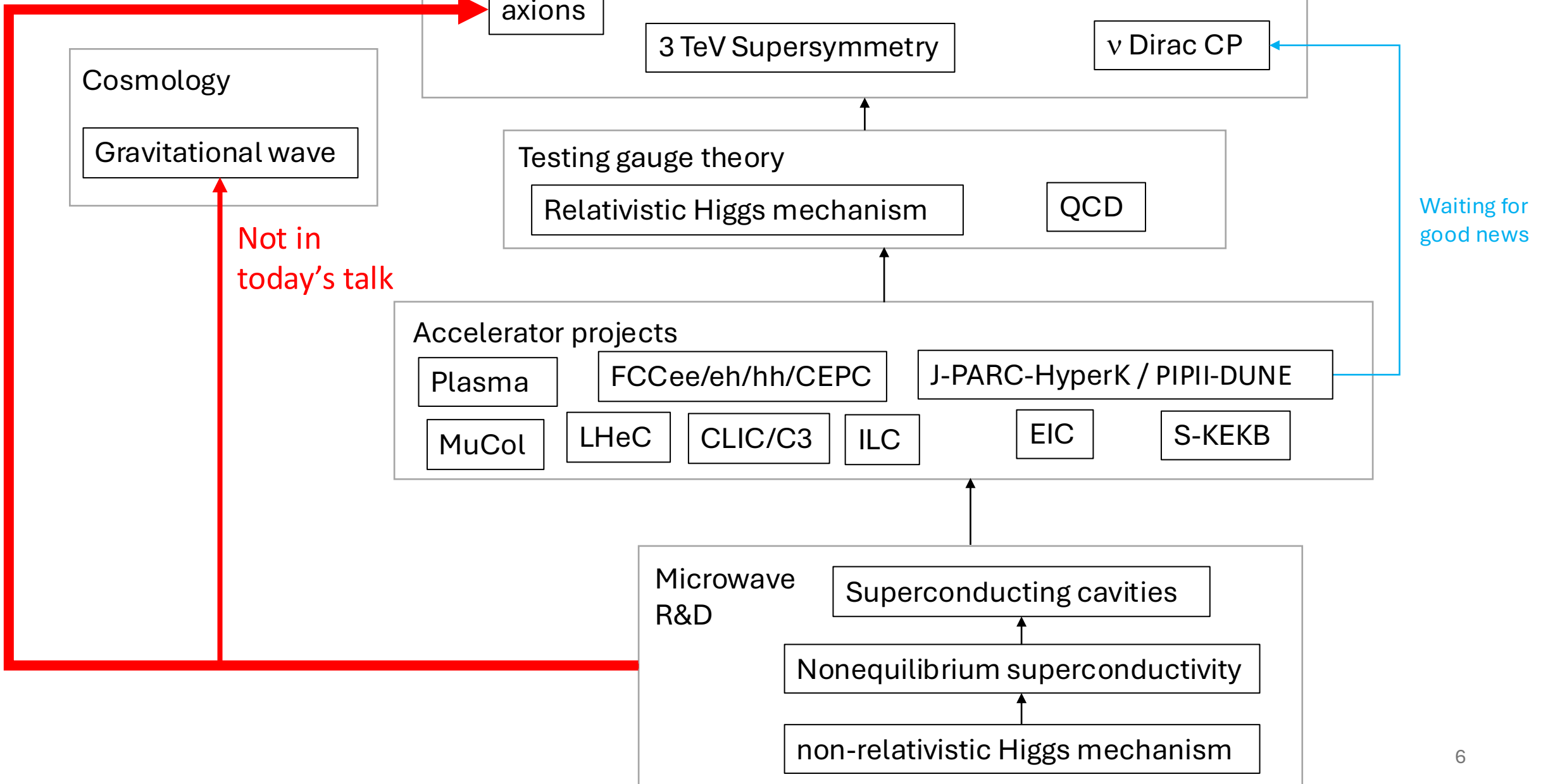

Outline

- We need new physics!
- DM axion as classical waves
- Axions at higher mass
- Quantum sensing
- Conclusion

Outline

- We need new physics!
- DM axion as classical waves
- Axions at higher mass
- Quantum sensing
- Conclusion

Clear need for new physics: e.g. Dark Matter (DM)

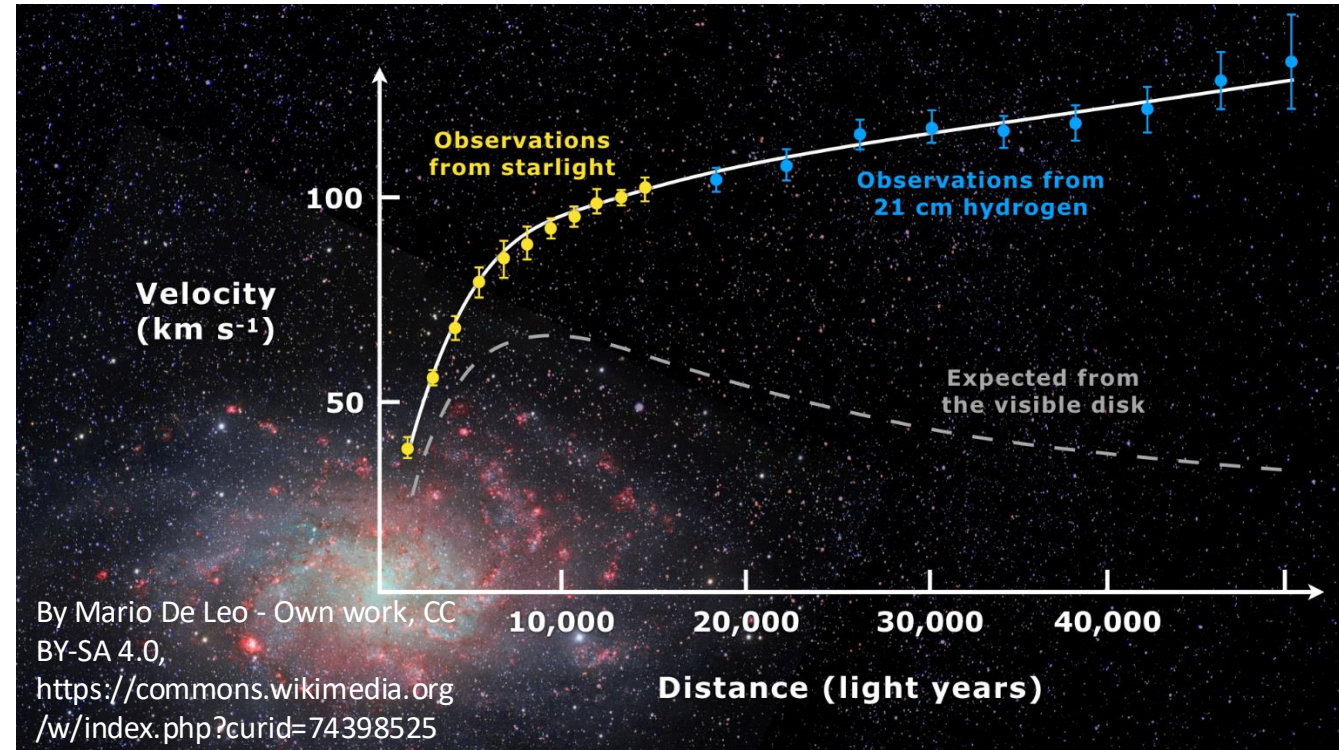
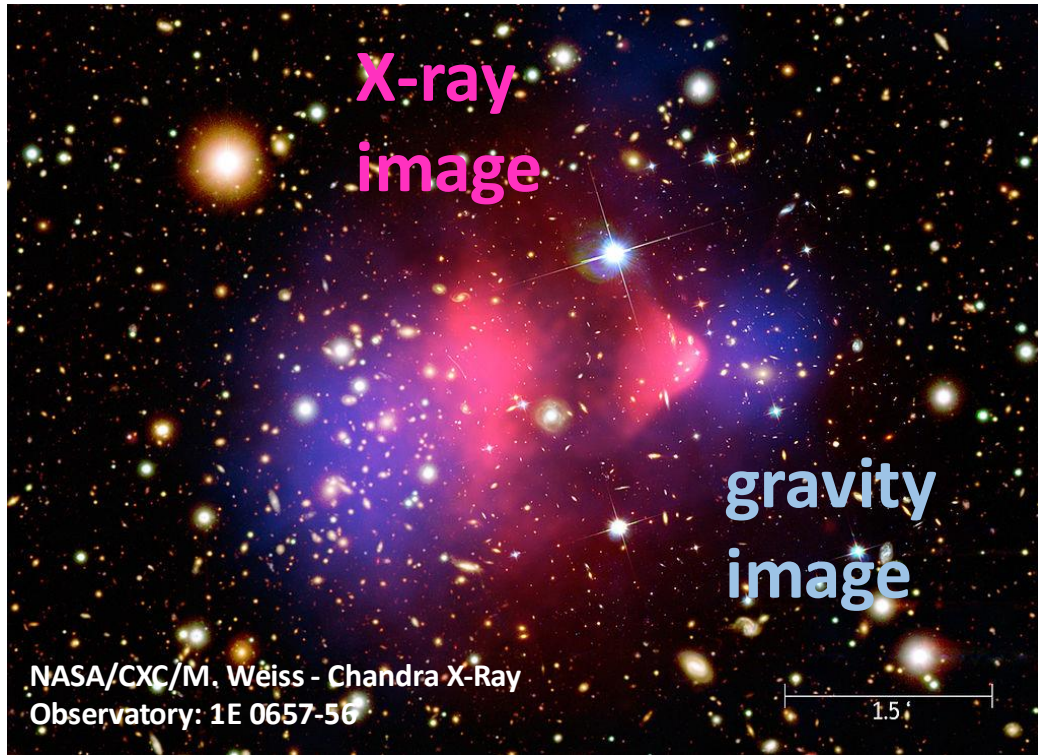

~~Neutrino?~~

~~Dark astrophysical objects?~~

~~Modified gravity?~~ van Dokkum, et al. *Nature* 555, 629–632 (2018)

Primordial black holes?

✓ Hypothetical new particles linked to **intrinsic issues** in the Standard Model?

Weakly Interacting Massive Particles (WIMPs)

Direct search

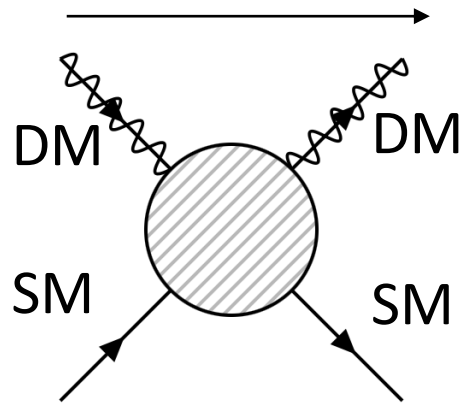

Indirect search

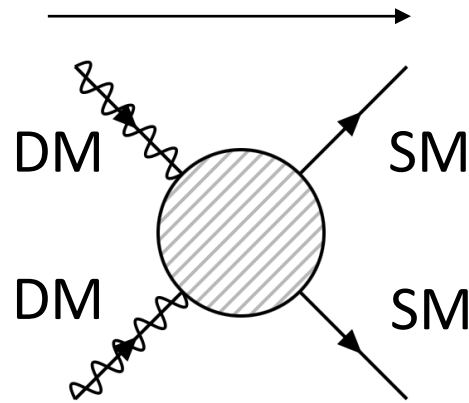

Accelerator production

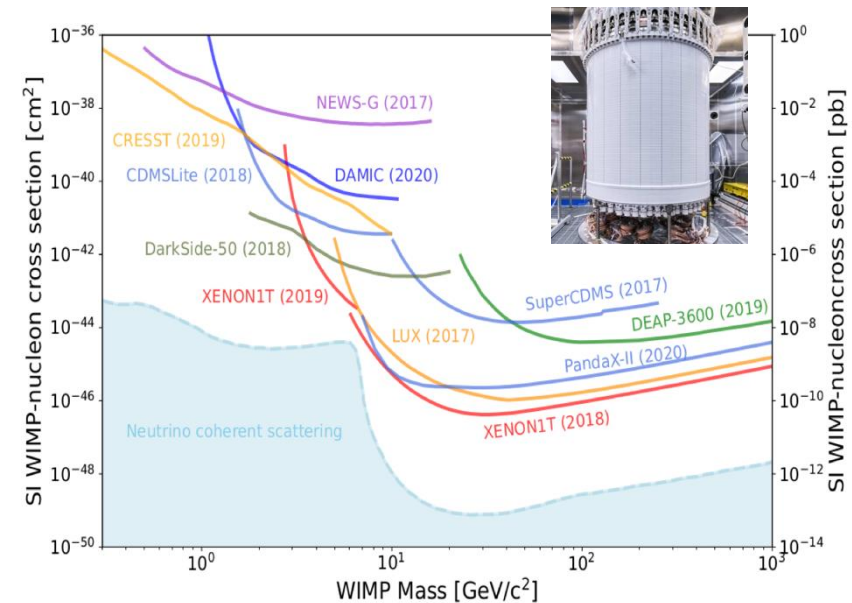
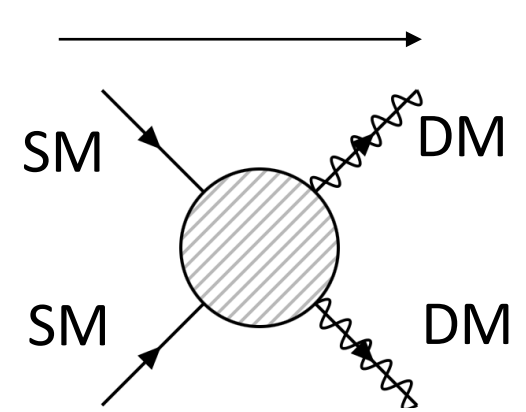

PDG2022

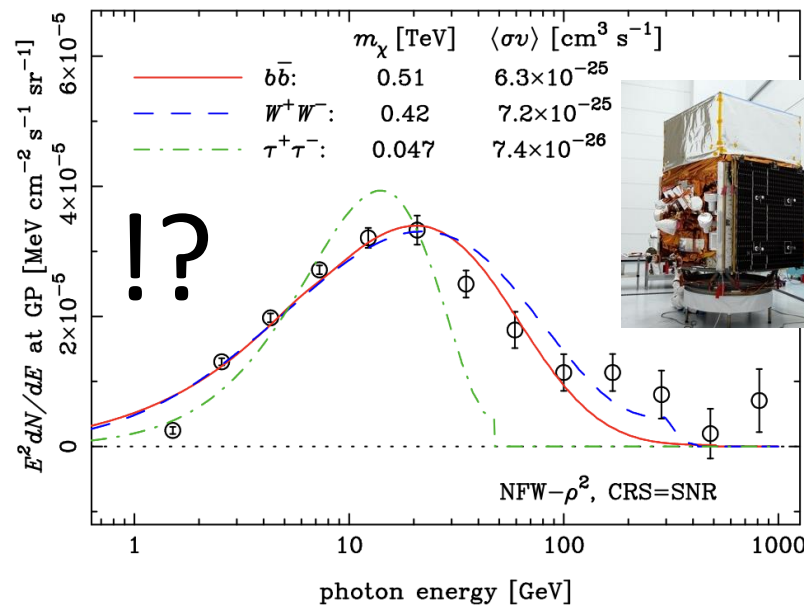

T. Totani arXiv:2507.07209

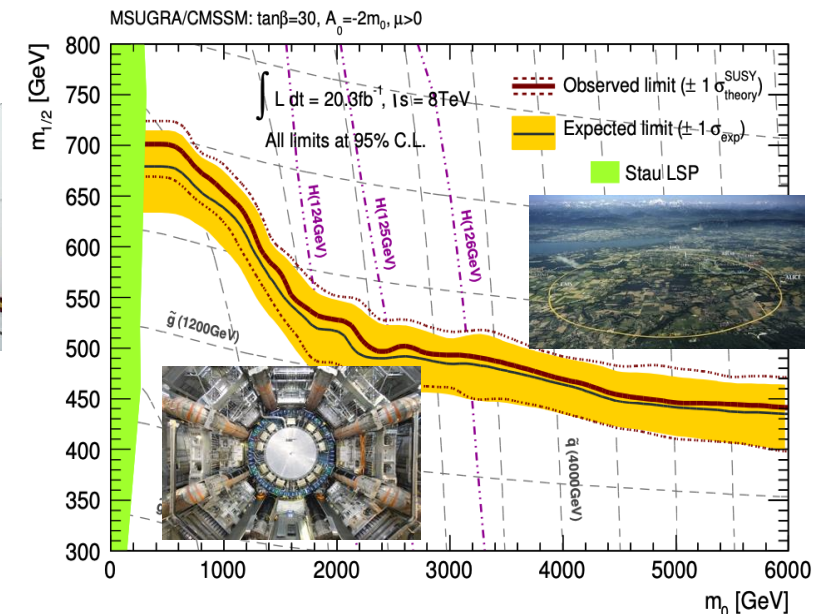

Y. Sasaki PhD thesis₁

Axions: a byproduct to cancel the strong CP

Quantum Chromodynamics includes

$$L_{QCD} \supset -\frac{1}{4} G_{\mu\nu}^a G^{\mu\nu a} + \frac{g_s^2}{32\pi^2} \theta G_{\mu\nu}^a \tilde{G}^{\mu\nu a}$$

This term generates electric dipole moment in neutron

- Theory: $d_n \sim (2.4 \pm 1.0) \times 10^{-3} \theta$ efm
 - Experiment: $|d_n| < 1.8 \times 10^{-13}$ efm
- SciPost Phys. Lect. Notes 45 (2022)

$$\rightarrow |\theta| < 0.8 \times 10^{-10} \ll 1$$

Naturalness problem without anthropic solution

Introduce a new global chiral U(1) (PQ symmetry) field a

$$\frac{g_s^2}{32\pi^2} \left(\theta + \frac{a}{F_a} \right) G_{\mu\nu}^a \tilde{G}^{\mu\nu a} \rightarrow 0 \text{ (after SSB)}$$

Spontaneous Symmetry Breaking

→ A Nambu-Goldston boson appears as a byproduct = **axion**

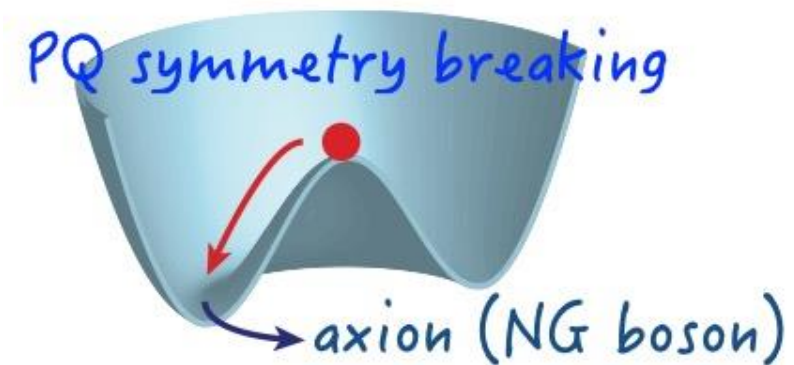

Axion as dark matter (PQ scale > inflation)

Axion loses kinetic energy *non-thermally* by coherent oscillation in the PQ potential

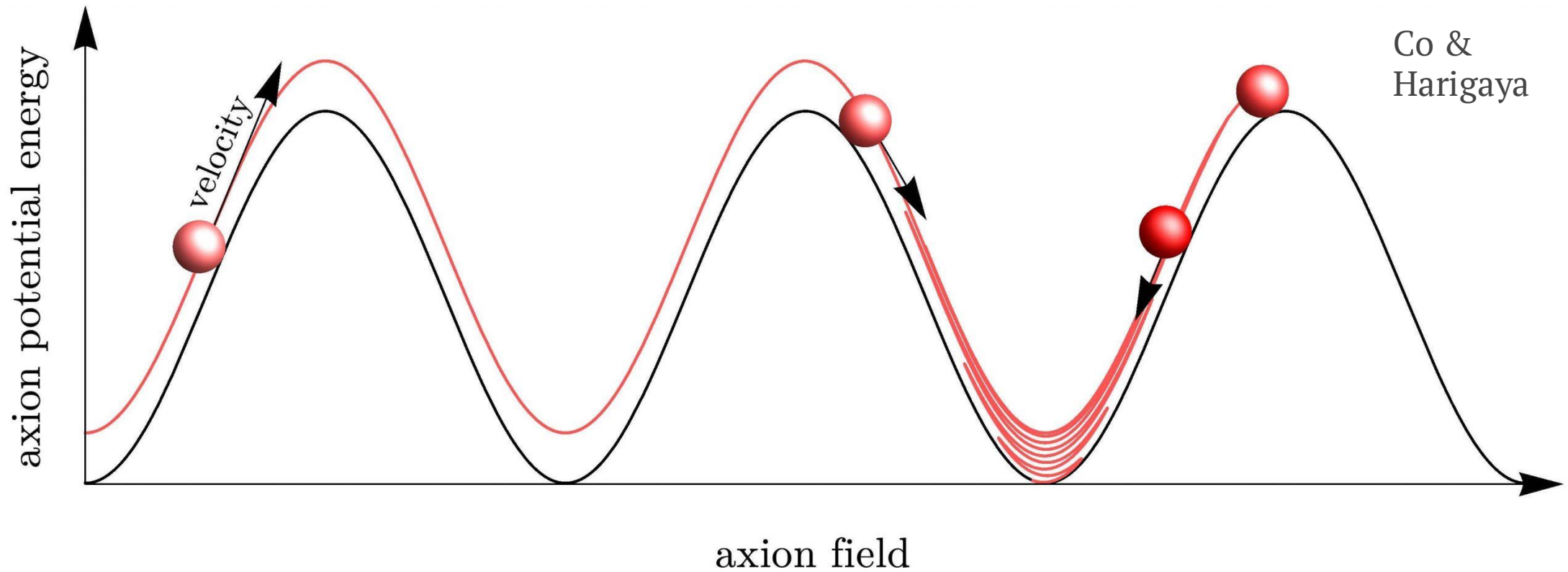

Misalignment
mechanism

$$\frac{d^2 a}{dt^2} + 3\boxed{H(t)} \frac{da}{dt} + m_a(T)^2 a = 0$$

Hubble parameter: friction \rightarrow “cooling” down

Outline

- We need new physics!
- **DM axion as classical waves**
- Axions at higher mass
- Quantum sensing
- Conclusion

De Broglie wavelength λ_B vs density of DM \bar{n}

- We are moving in the **galaxy halo of dark matter** with speed of 220 km/s $\rightarrow \beta \sim 0.07\%$
- **Galaxy halo of dark matter density** $\rho \sim 0.45 \text{ GeV/cm}^3$

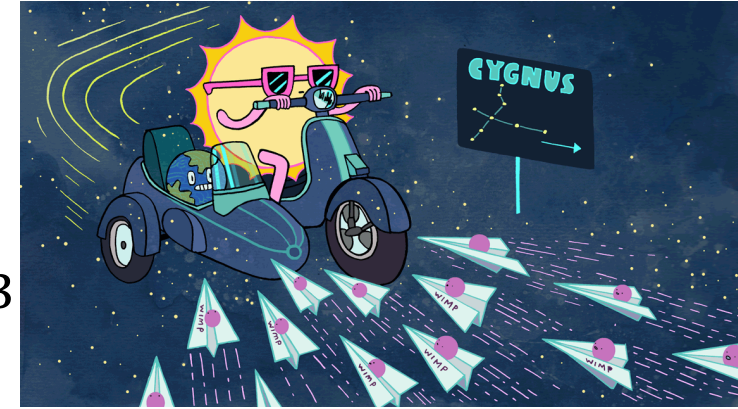

<https://www.symmetrymagazine.org/article/wimps-in-the-dark-matter-wind> Artwork by Sandbox Studio, Chicago with Corinne Mucha

WIMP:

$$\lambda_B \sim \frac{m \sim 1 \text{ TeV (Higgsino)}}{2\pi \times 196 \text{ MeVfm}} \frac{1}{0.07\% \times 1 \text{ TeV}} = 1.8 \text{ fm}$$

$$\bar{n} \sim \frac{0.45 \text{ GeV/cm}^3}{1 \text{ TeV}} \sim 10^{-3} \text{ cm}^{-3}$$

$$\rightarrow \bar{n} \ll \frac{1}{\lambda^3}$$

WIMP behaves as a particle

Axions: $m \sim 10 \mu\text{eV}$

$$\lambda_B \sim \frac{2\pi \times 196 \text{ MeVfm}}{0.07\% \times 10 \mu\text{eV}} = 176 \text{ m}$$

$$\bar{n} \sim \frac{0.45 \text{ GeV/cm}^3}{10 \mu\text{eV}} \sim 10^{13} \text{ cm}^{-3}$$

$$\rightarrow \bar{n} \gg \frac{1}{\lambda^3}$$

DM axions behave as a classical wave

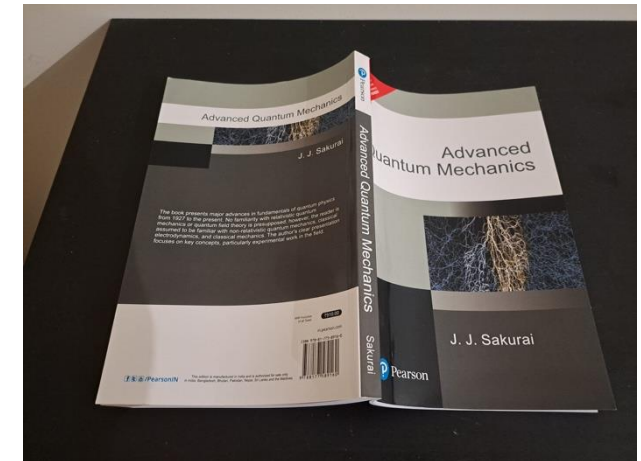

$$E_{cl}^2 = \frac{\bar{n}}{\lambda} \gg \frac{1}{\lambda^4} \sim \langle 0 | \hat{E} \cdot \hat{E} | 0 \rangle$$

Standard model of dark matter axion distribution function

Velocity dispersion of Milky way Galaxy around

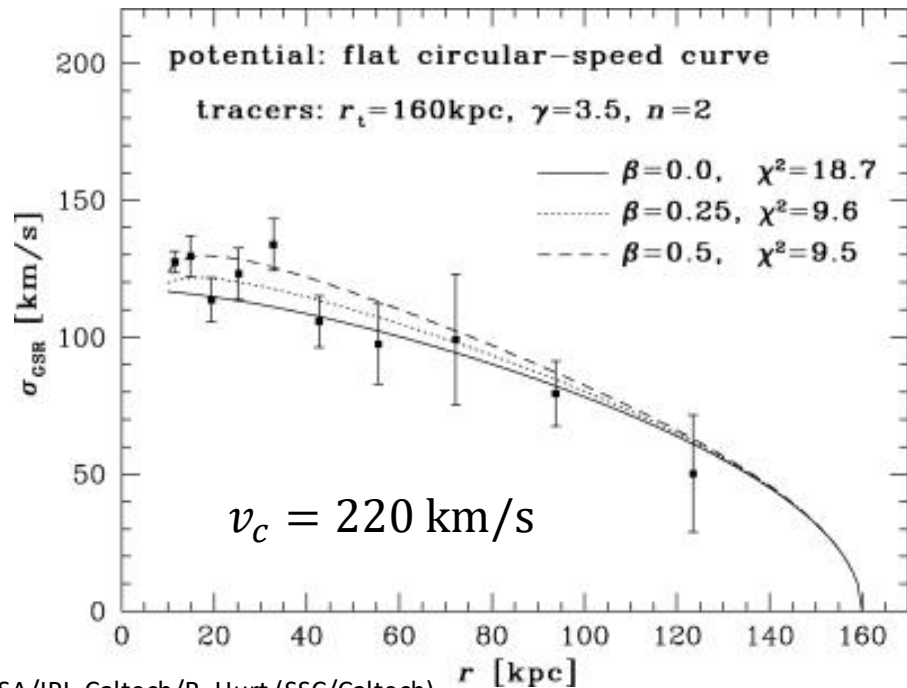

$$f(\omega) = P_0 \theta(\omega - m_a) 2\omega_0^{-\frac{3}{2}} \sqrt{\frac{\omega - m_a}{\pi}} \exp\left(-\frac{\omega - m_a}{\omega_0}\right)$$

If $m_a = 10 \text{ GHz}$

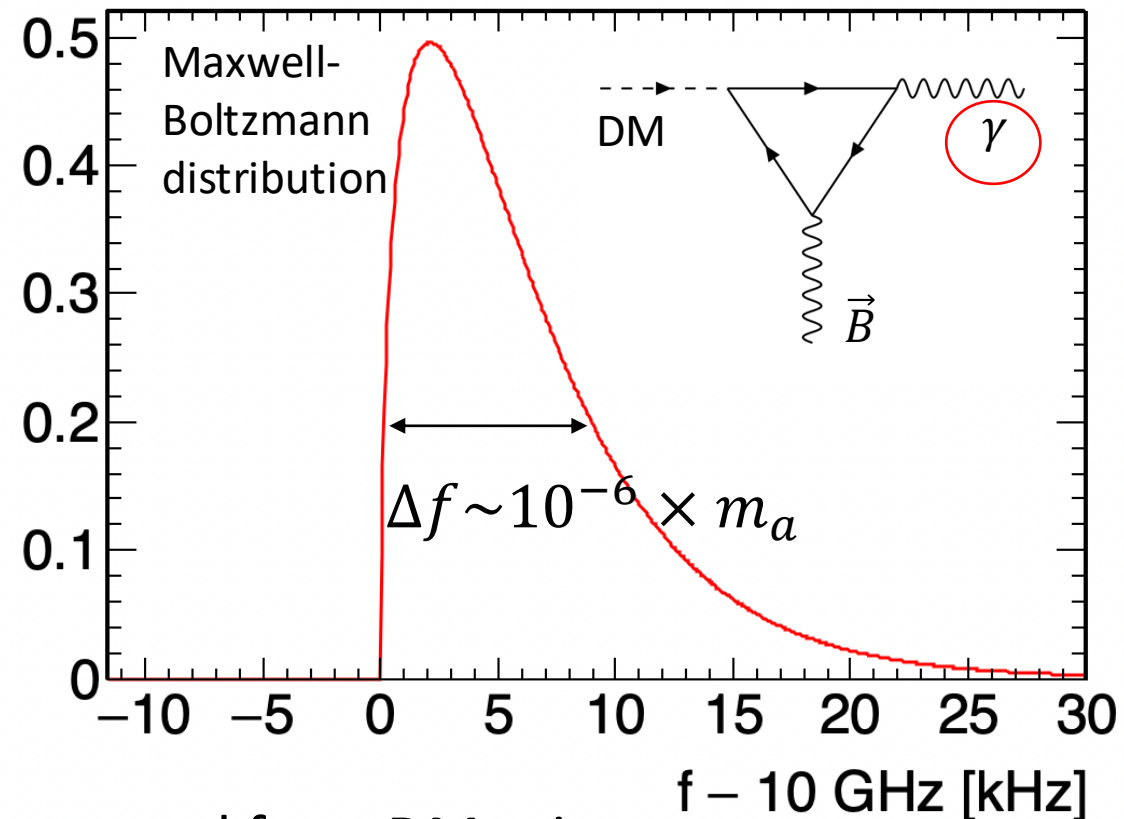

Microwaves converted from DM axion is very narrow band classical waves

Wakefield links accelerators & axion dark matter detectors

$$\begin{cases} \nabla \cdot \mathbf{D} = \rho(t, \mathbf{r}) \\ \nabla \times \mathbf{H} - \dot{\mathbf{D}} = \mathbf{J}(t, \mathbf{r}) \\ \nabla \cdot \mathbf{B} = 0 \\ \nabla \times \mathbf{E} + \dot{\mathbf{B}} = 0 \end{cases}$$

Accelerator as a resonator

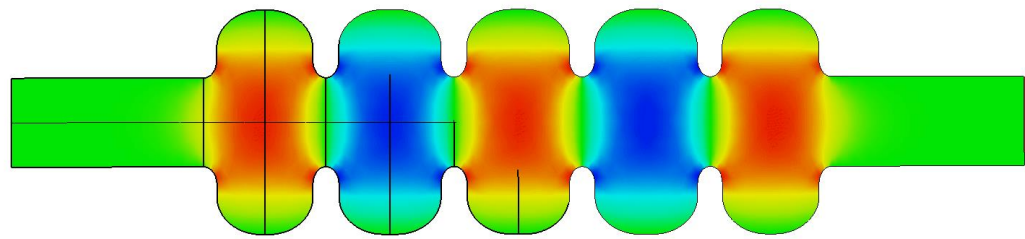

Driven by RF source via coupler

Accelerator as an oscillator

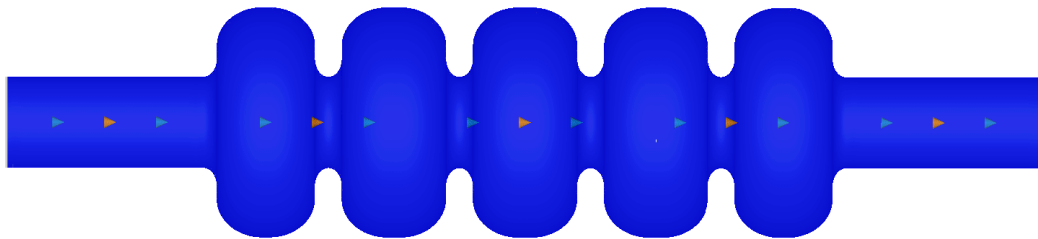

Wakefield by high current e-/e+ beam (crucial in FCCee collider) $\tan \beta$

$$\begin{cases} \nabla \cdot \mathbf{D} = \cancel{\rho(t, \mathbf{r})} - g_{a\gamma} \mathbf{B}_e \cdot \nabla a \\ \nabla \times \mathbf{H} - \dot{\mathbf{D}} = \cancel{\mathbf{J}(t, \mathbf{r})} + g_{a\gamma} (\dot{\mathbf{a}} \mathbf{B}_e - \mathbf{E}_e \times \nabla a) \\ \nabla \cdot \mathbf{B} = 0 \\ \nabla \times \mathbf{E} + \dot{\mathbf{B}} = 0 \end{cases}$$

Detector as a resonator

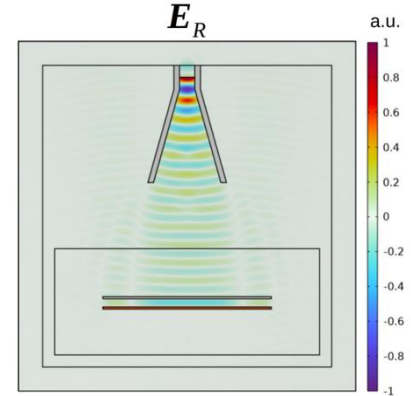

Driven by MW source via antenna



Jacob Egge PhD thesis

detector as an oscillator

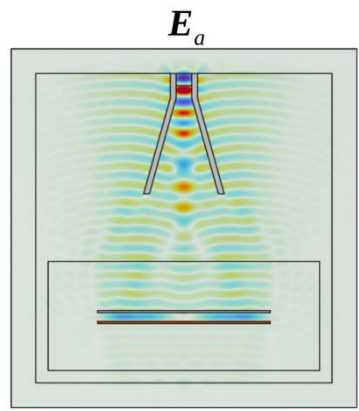
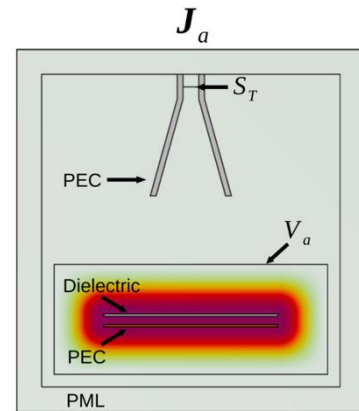

Wakefield by dark matter axions m_a

Classical electrodynamics is the mean to hunt axions

Skivie haloscope

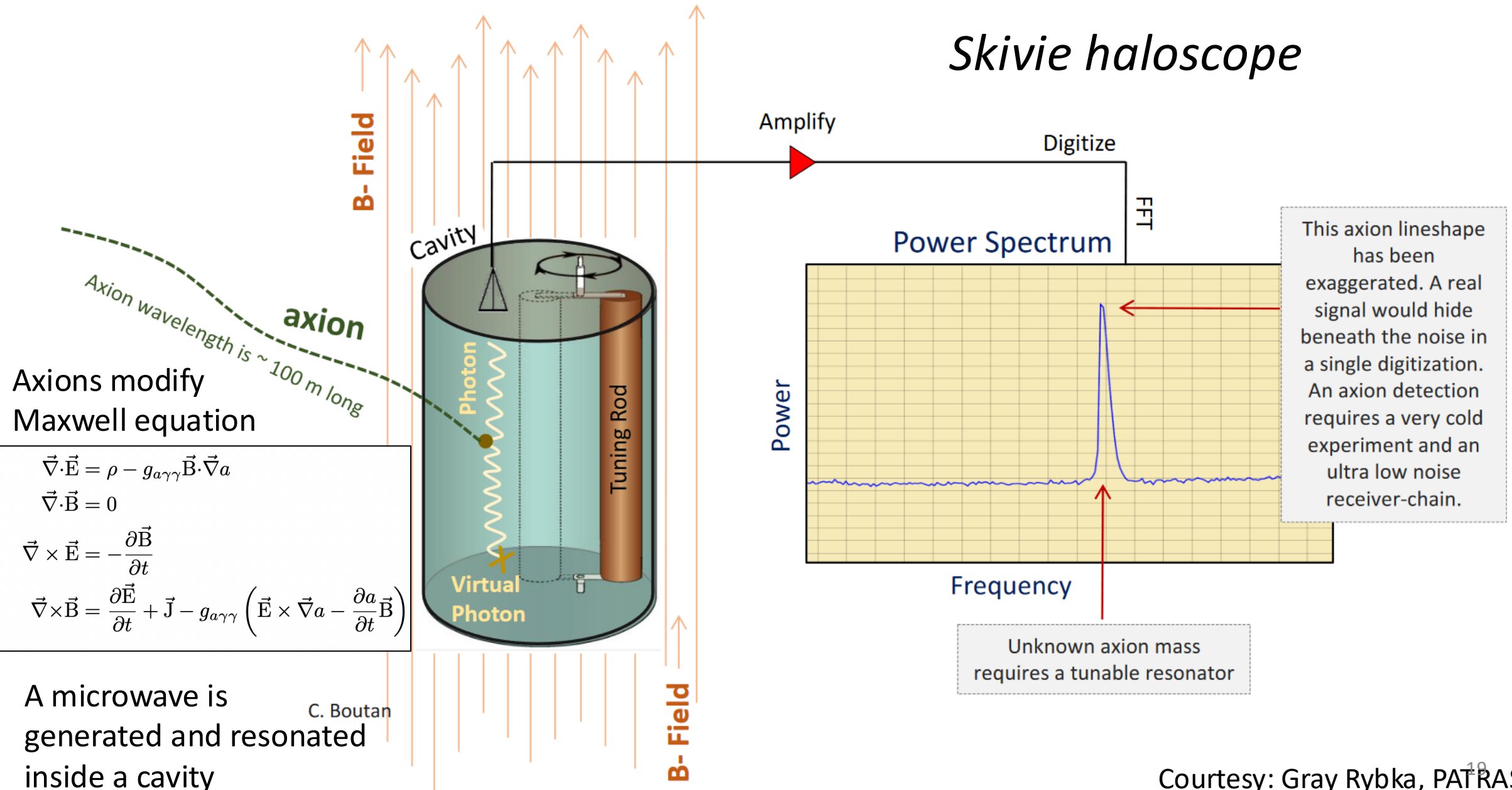

Axions modify Maxwell equation

$$\begin{aligned} \vec{\nabla} \cdot \vec{E} &= \rho - g_{a\gamma\gamma} \vec{B} \cdot \vec{\nabla} a \\ \vec{\nabla} \cdot \vec{B} &= 0 \\ \vec{\nabla} \times \vec{E} &= -\frac{\partial \vec{B}}{\partial t} \\ \vec{\nabla} \times \vec{B} &= \frac{\partial \vec{E}}{\partial t} + \vec{J} - g_{a\gamma\gamma} \left(\vec{E} \times \vec{\nabla} a - \frac{\partial a}{\partial t} \vec{B} \right) \end{aligned}$$

A microwave is generated and resonated inside a cavity

C. Boutan

Photon (energy) detection vs wave detection

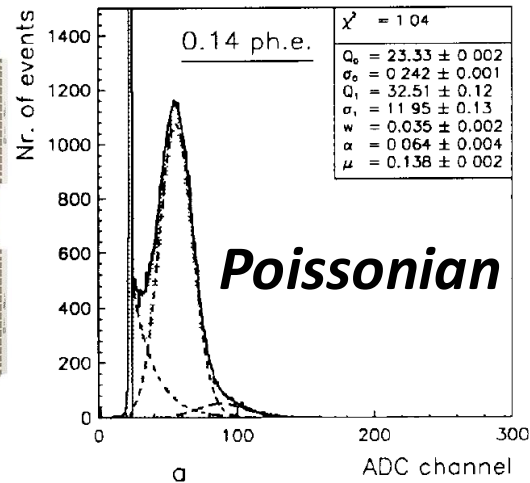
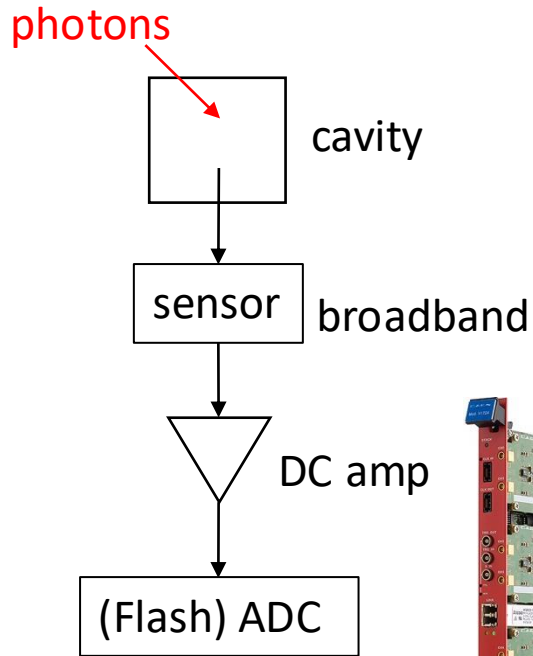

$$P(t) = n \times \hbar\omega \propto V_{ADC}(t)$$

$$\Delta\phi\Delta n > 1$$

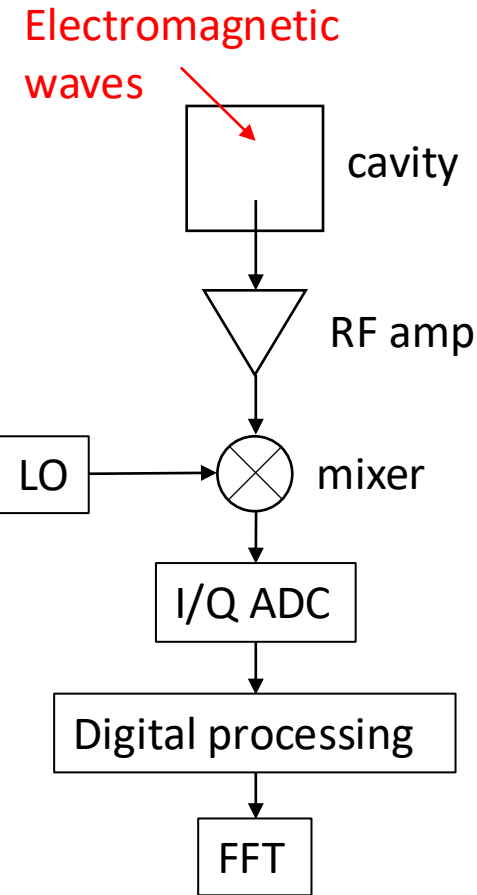

I/Q Demodulator

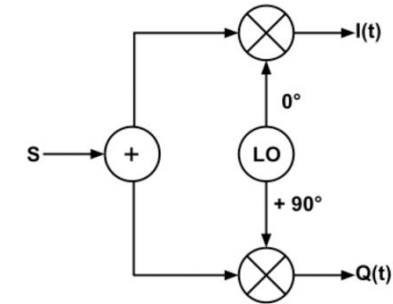

From wikipedia

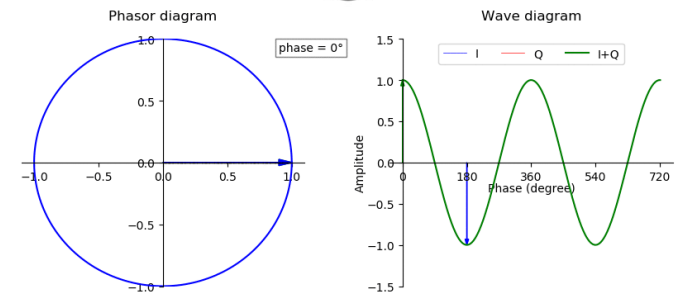

$$RF(t) = I(t) \cos(\omega t) + Q(t) \sin(\omega t)$$

$$\rightarrow P(\omega) = \tilde{I}^2(\omega) + \tilde{Q}^2(\omega)$$

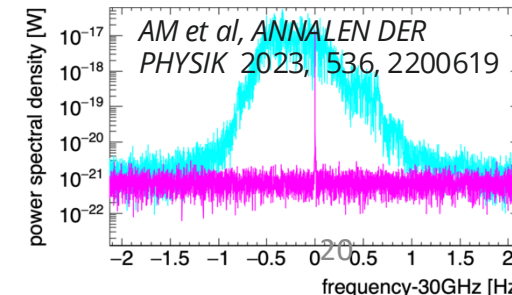

Photon (energy) detection vs wave detection

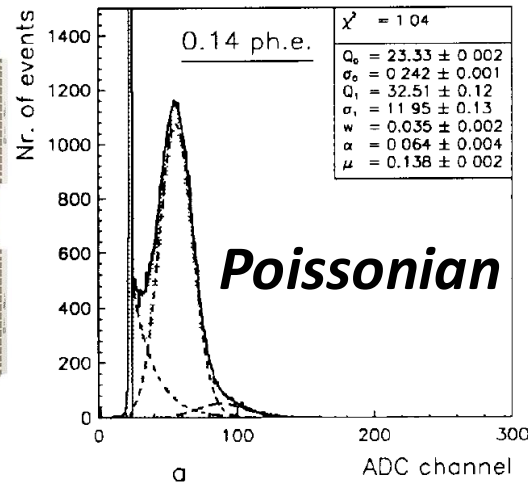
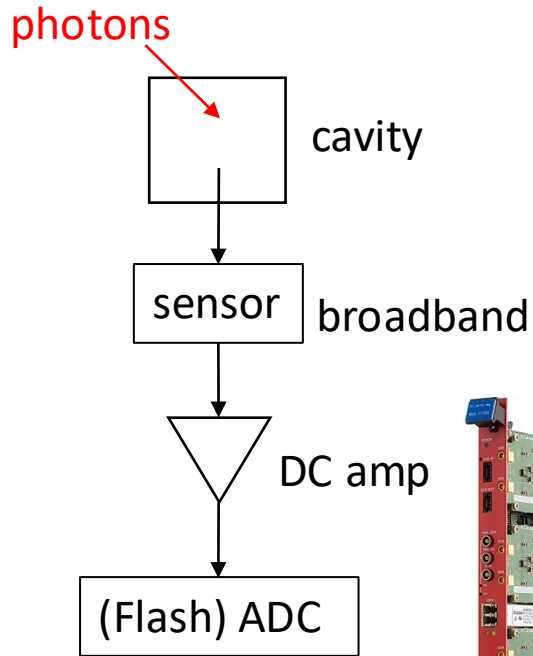

$$P(t) = n \times \hbar\omega \propto V_{ADC}(t)$$

$$\Delta\phi\Delta n > 1$$

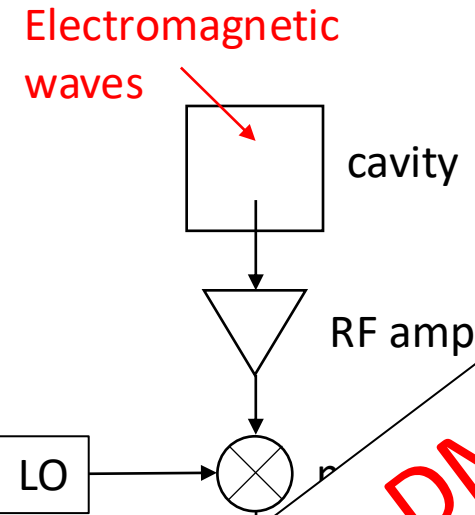

Standard in DM axion searches and RF accelerating cavities

$$RF(t) = I \cos(\omega t) + Q(t) \sin(\omega t)$$

$$\rightarrow P(\omega) = \tilde{I}^2(\omega) + \tilde{Q}^2(\omega)$$

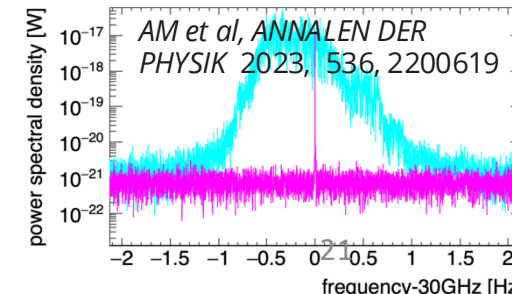
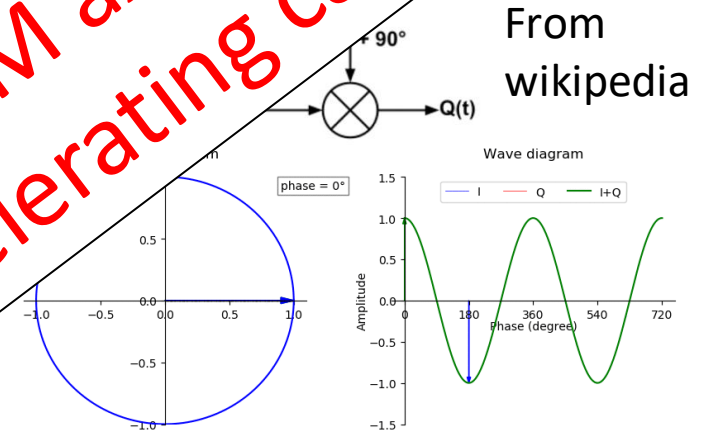

Axion Dark Matter eXperiment (ADMX)

arXiv:2010.00169

Signal to Noise Ratio is the key for discovery

- Signal is a narrow peak ($f/\Delta f \sim 10^6$) from axion

$$P_S = (1.0 \times 10^{-22} \text{ W}) \times \left(\frac{V}{136\text{L}}\right) \left(\frac{B}{6.8\text{T}}\right)^2 \left(\frac{C}{0.4}\right) \left(\frac{g}{0.97}\right)^2 \left(\frac{\rho}{0.45 \text{ GeV/cm}^3}\right) \left(\frac{f}{650 \text{ MHz}}\right) \left(\frac{Q}{50000}\right)$$

- Johnson Nyquist noise power

$$P_N = k_B T_S = 1.4 \times 10^{-23} \left(\frac{T_S}{1\text{K}}\right) \text{ W/Hz}$$

- Dicke's radiometer formula

$$S/N = \frac{P_S}{P_N} \sqrt{\frac{t}{b}}$$

t : integration time

b : measurement bandwidth

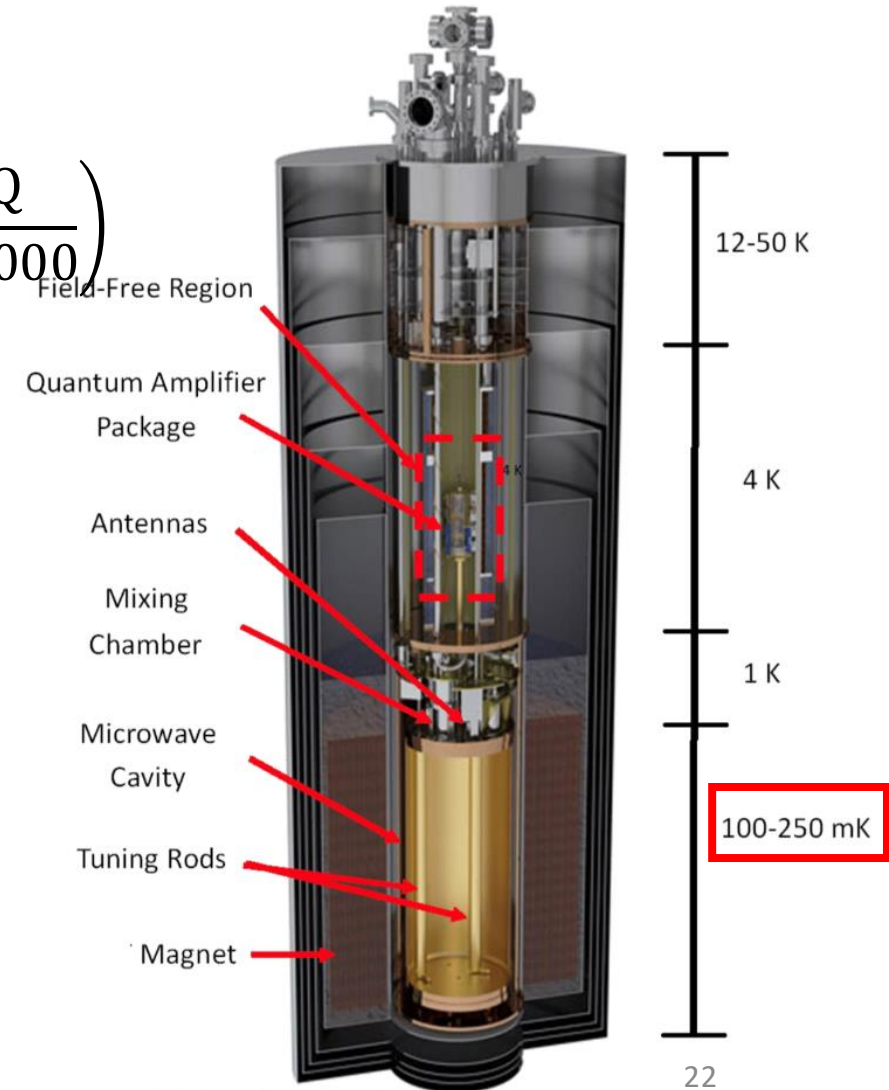
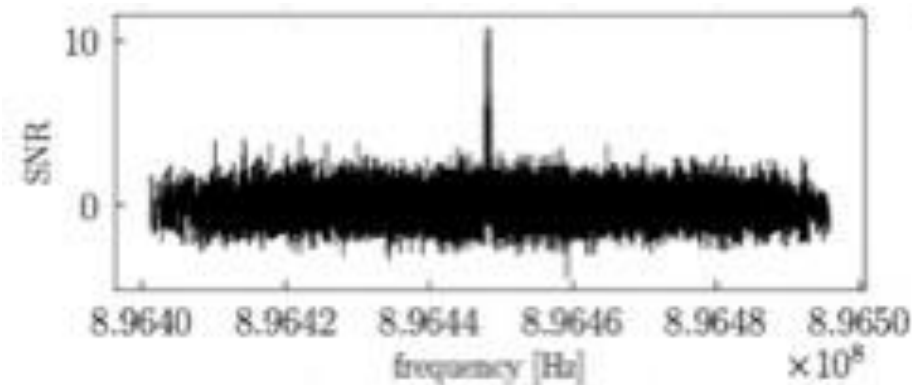

Outline

- We need new physics!
- DM axion as classical waves
- **Axions at higher mass**
- Quantum sensing
- Conclusion

From now

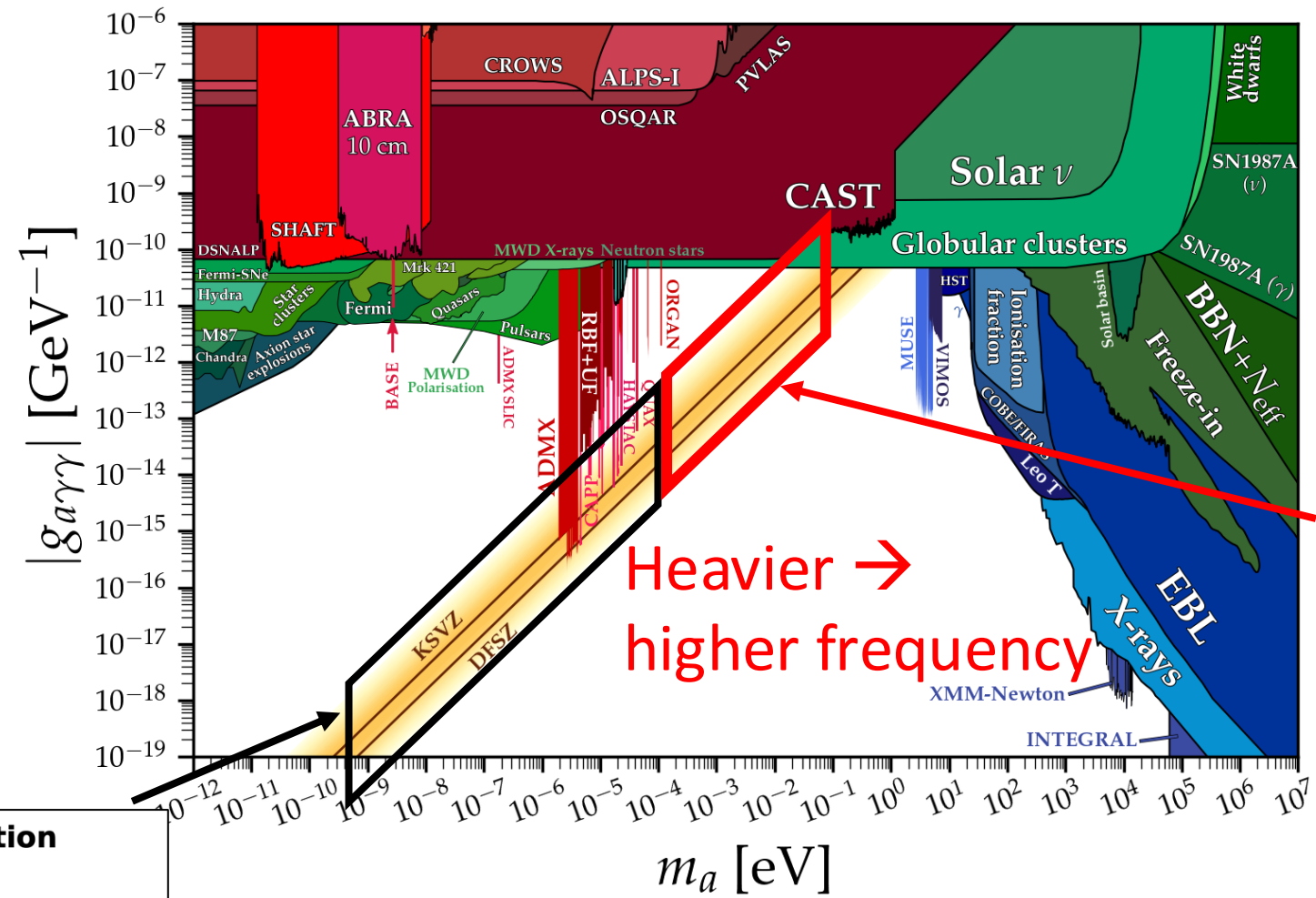

So far

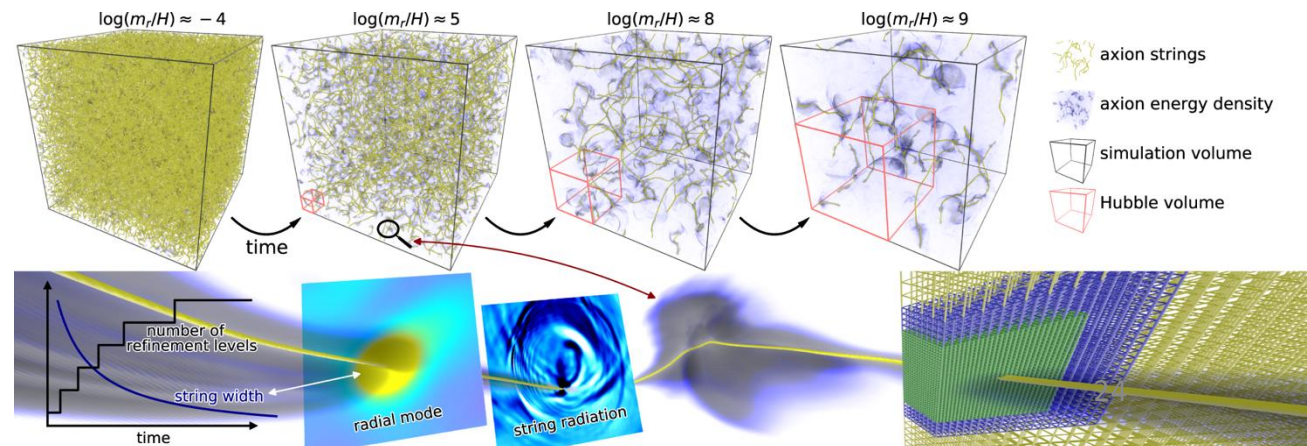
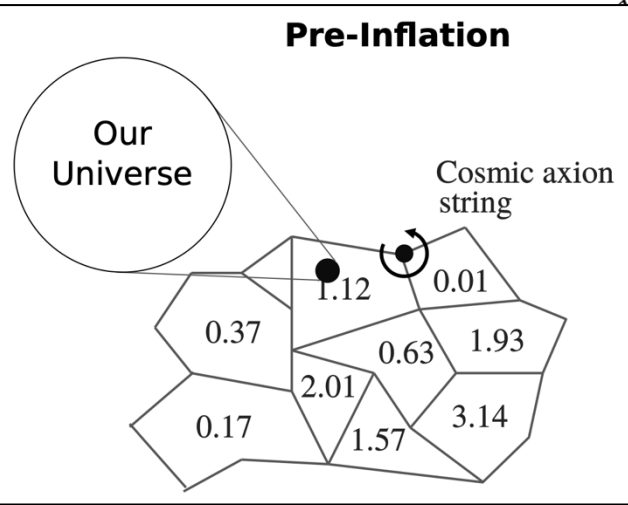
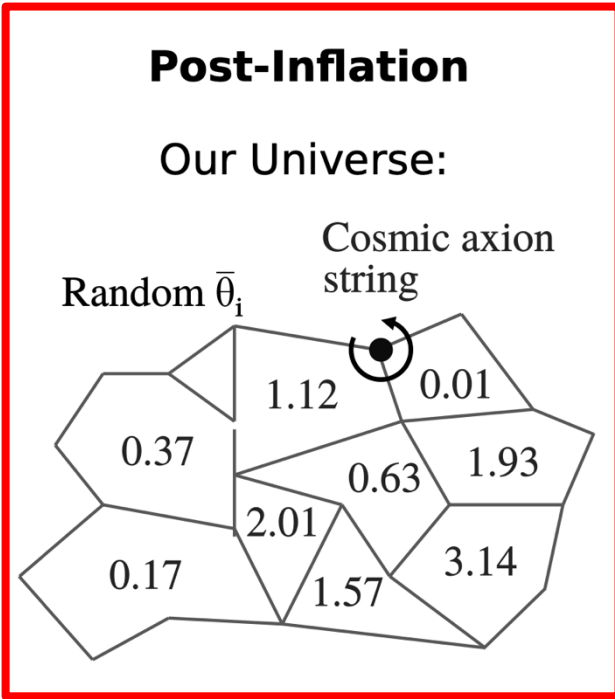

Buschmann, et al. *Nat Commun* **13**, 1049 (2022)

Issue of high-frequency resonators for dark matter search

An RF cavity (ADMX-type) becomes $V \sim f^{-3}$

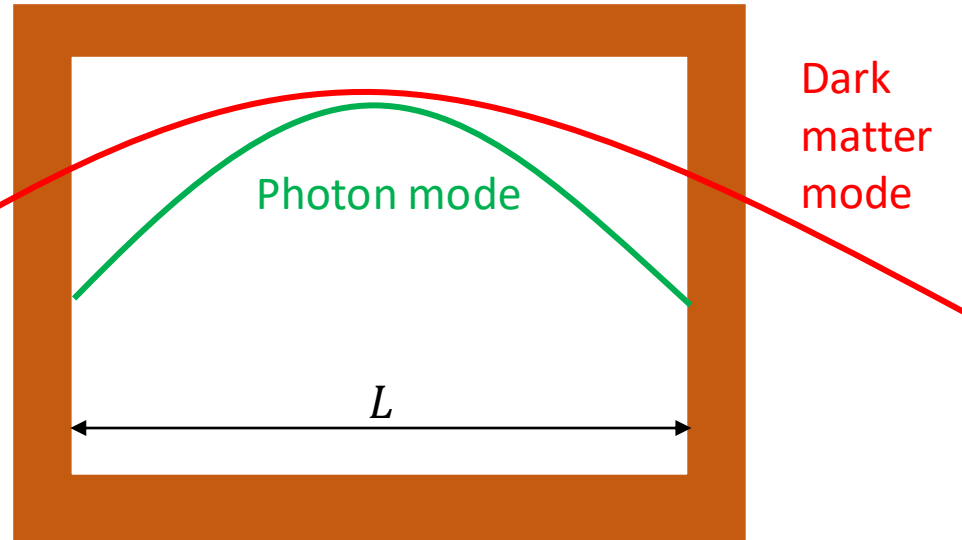

Signal: $\propto VQ$

The signal is lost by higher frequency

An over-sized cavity cancels the signal

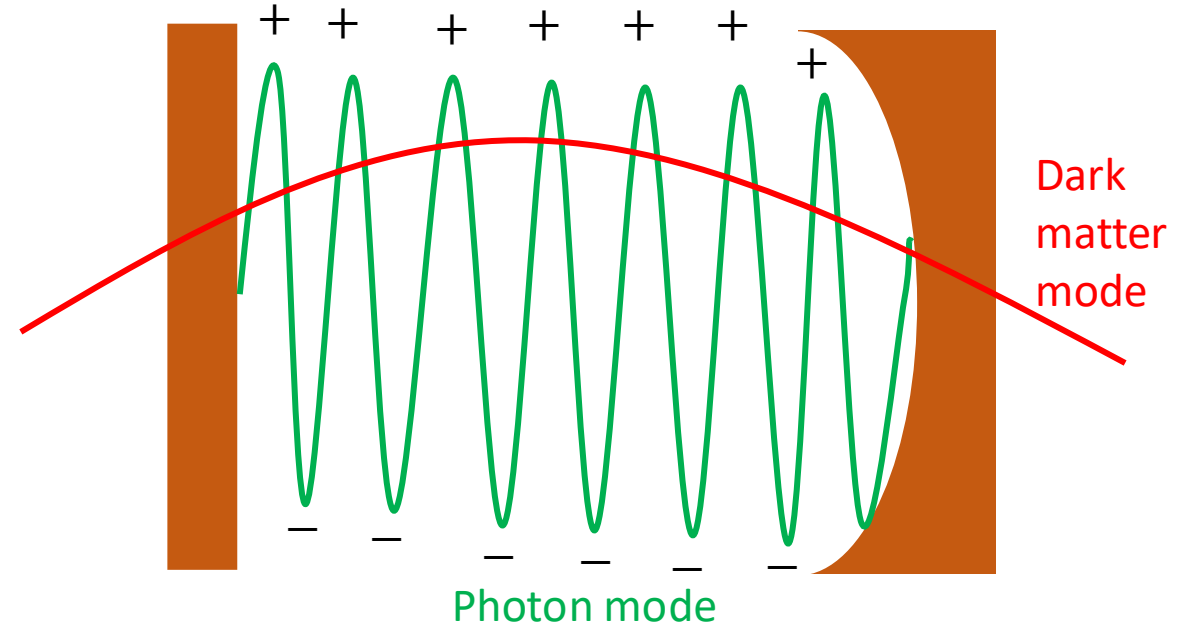

The dark matter is cold \rightarrow De Broglie wavelength is long

Spatial integral is cancelled!

\rightarrow We have needed an idea to keep the resonator size reasonable with high frequency without having polarity changes

Four ideas toward heavier axion dark matter

Multiple small cavities

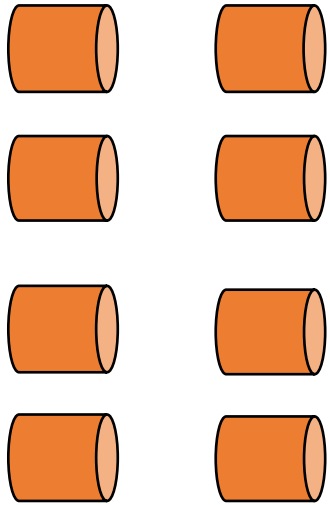

ADMX-EFR @ FNAL
CAST-CAPP @ CERN

Dish antenna

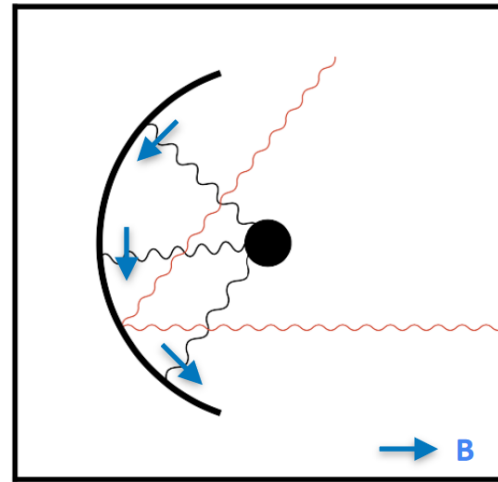

BRASS @ DESY
BREAD @ Uchicago
DAWA@CEA

Dielectric disks

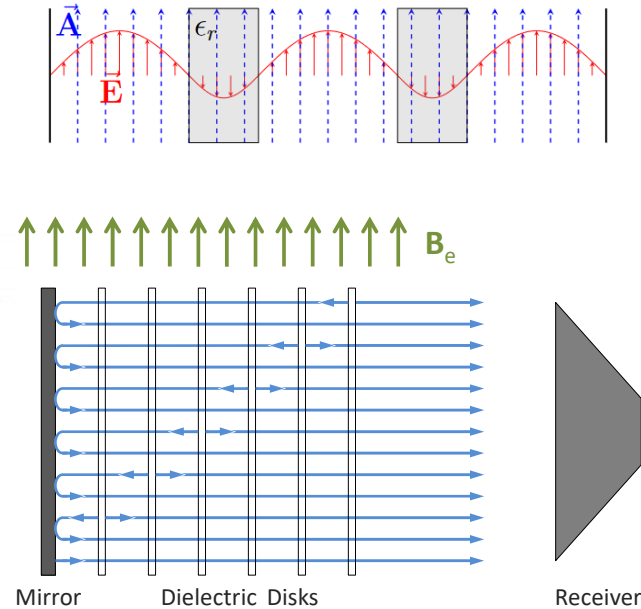

ORGAN @ Australia
ADMX-Orpheus @ US
MADMAX @ DESY

Wire metamaterial

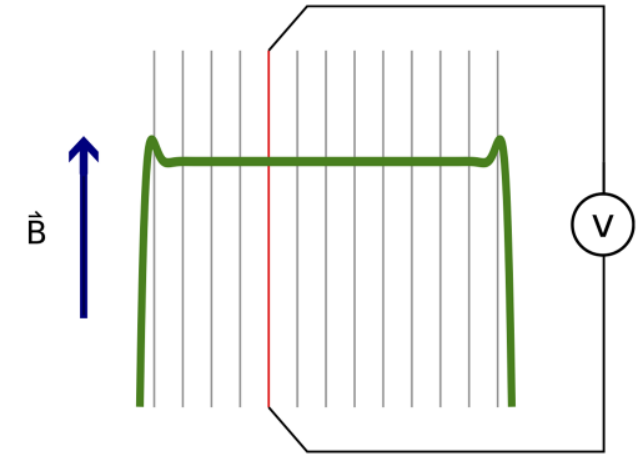

ALPHA @ SU+Ylae+UCB
New projects rising

Four ideas toward heavier axion dark matter

Multiple small cavities

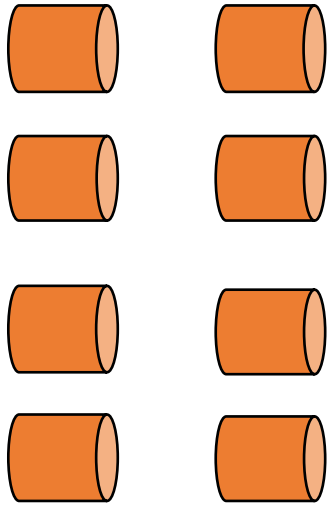

ADMX-EFR @ FNAL
CAST-CAPP @ CERN

Dish antenna

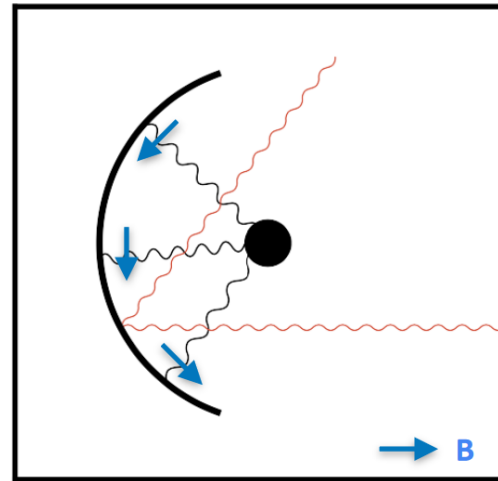

BRASS @ DESY
BREAD @ Uchicago
DAWA@CEA

Dielectric disks

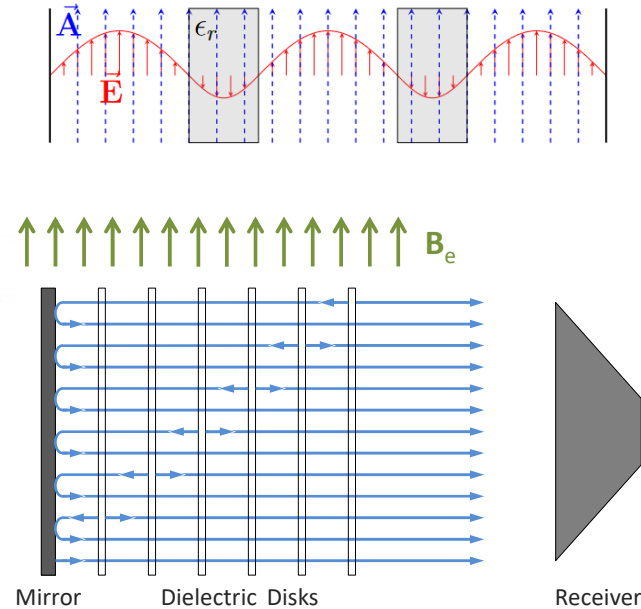

ORGAN @ Australia
ADMX-Orpheus @ US
MADMAX @ DESY

Wire metamaterial

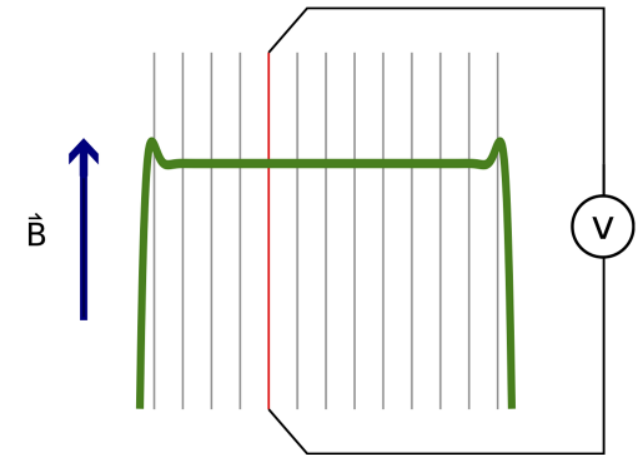

ALPHA @ SU+Ylae+UCB
New projects rising

MADMAX: multiple dielectric disks

- Avoid the negative overlap with **dielectric** disks
- Many disks to **boost** the signal
- Dipole magnet is mandatory

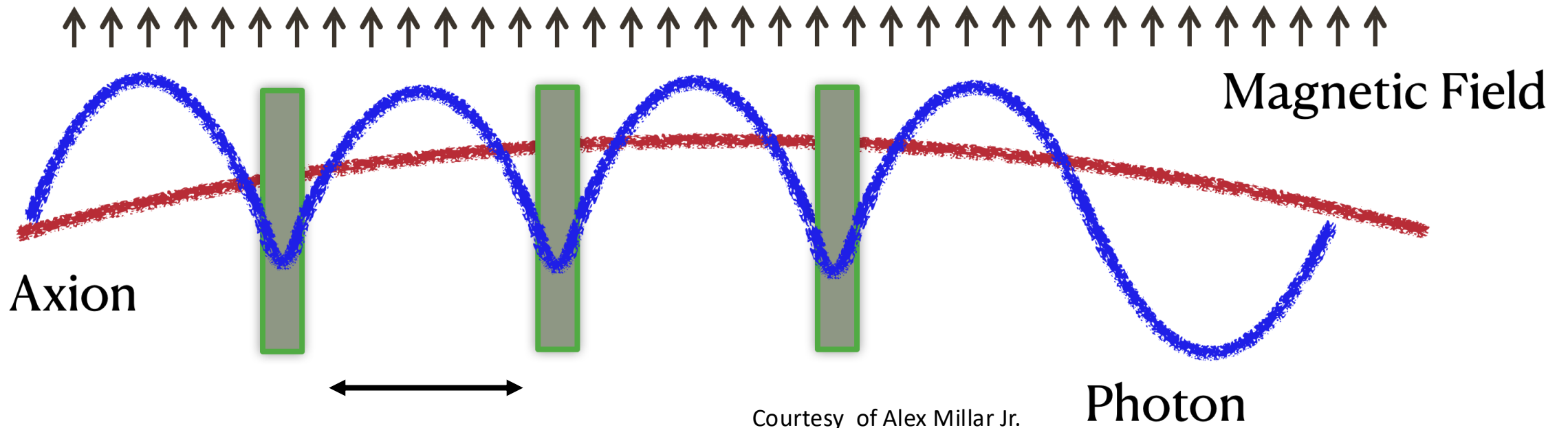
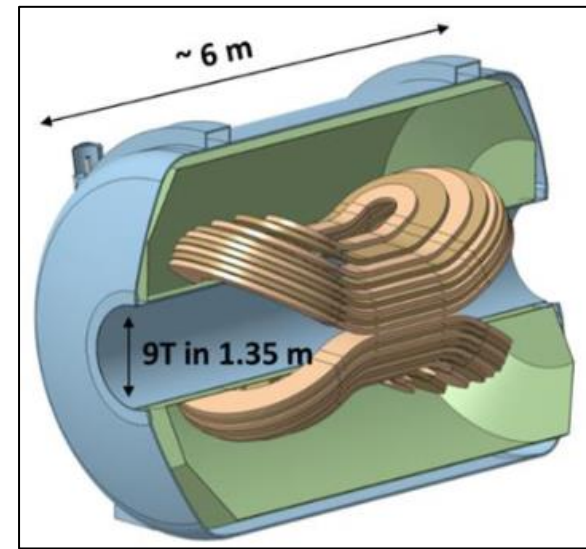

Courtesy of Alex Millar Jr.

Frequency tuning by moving disks with piezo

Current status and prospect of MADMAX

MADMAX collaboration, PRL 135, 041001 (2025)

MADMAX collaboration, PRL 134, 15, 151004 (2025)

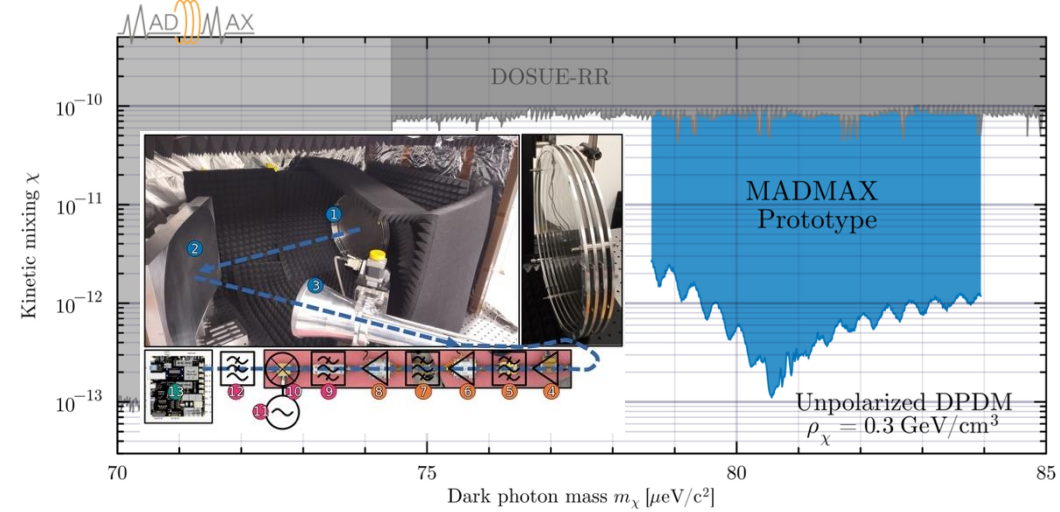
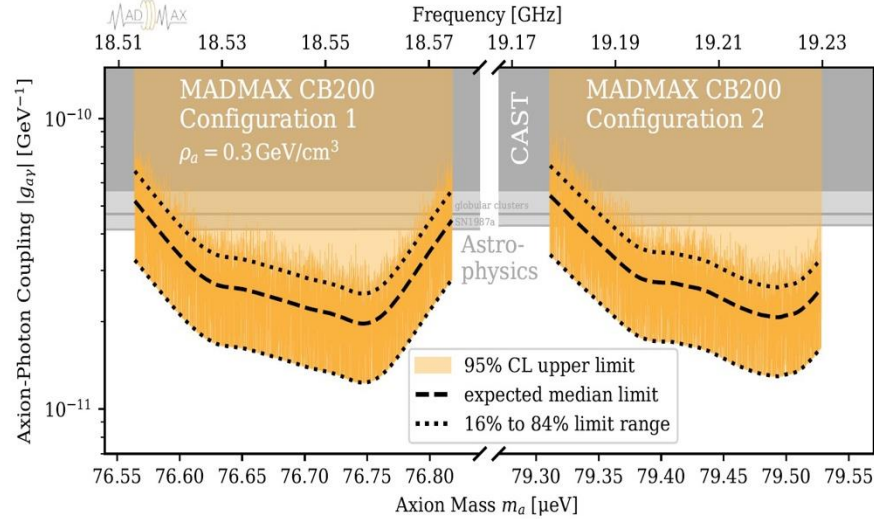

Scaling up

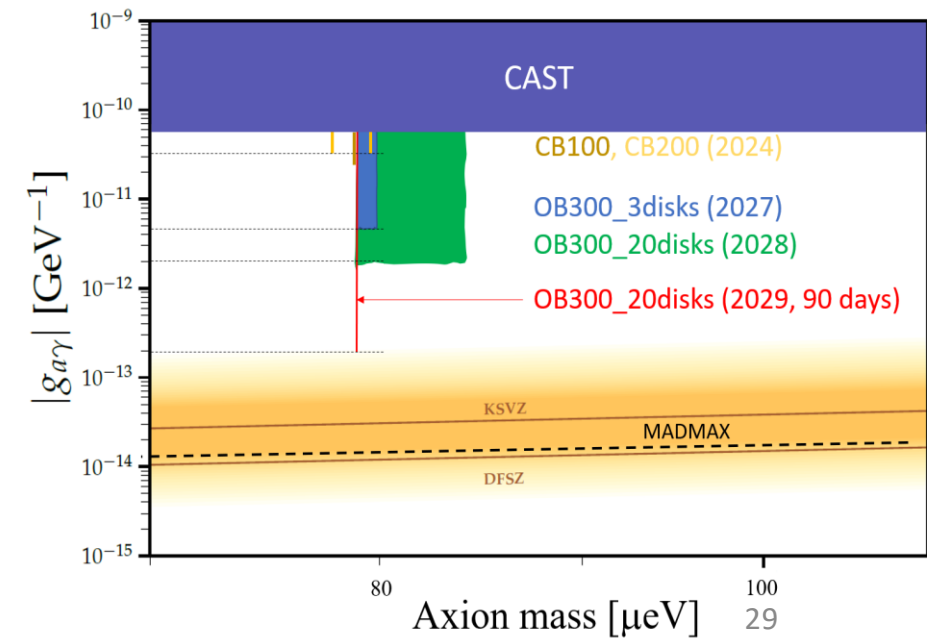
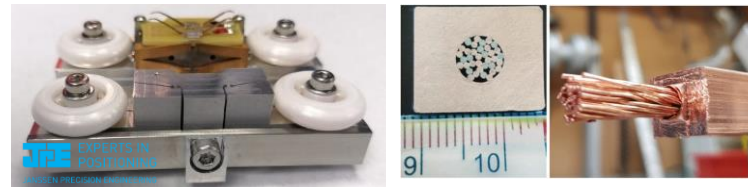
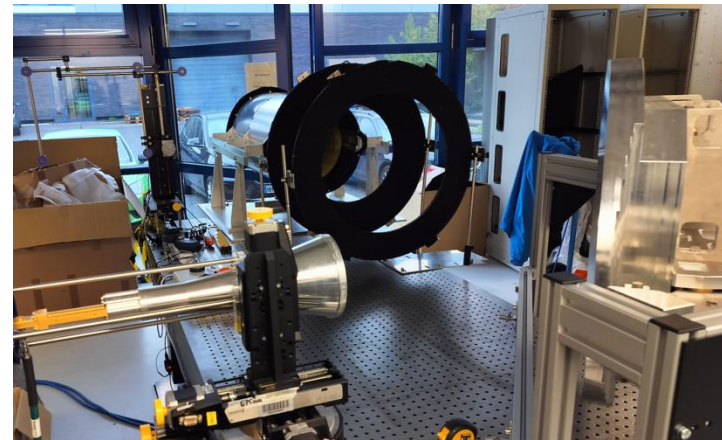

Status and prospect of

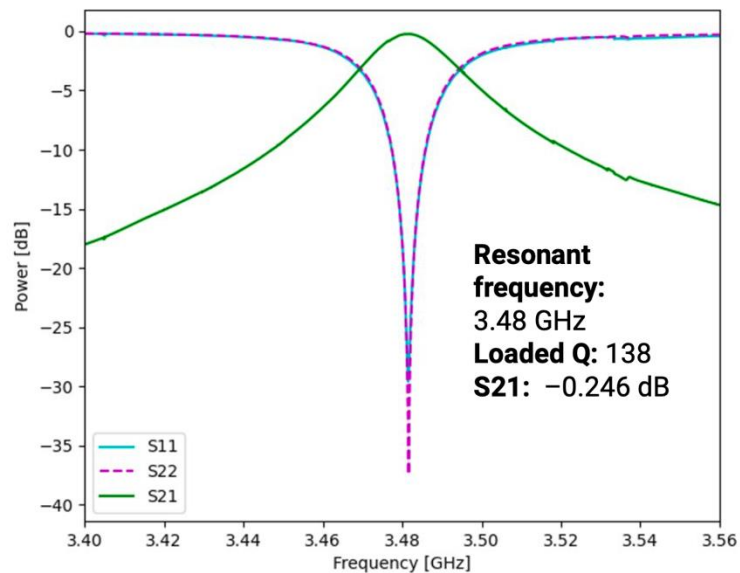

With wires 6x6

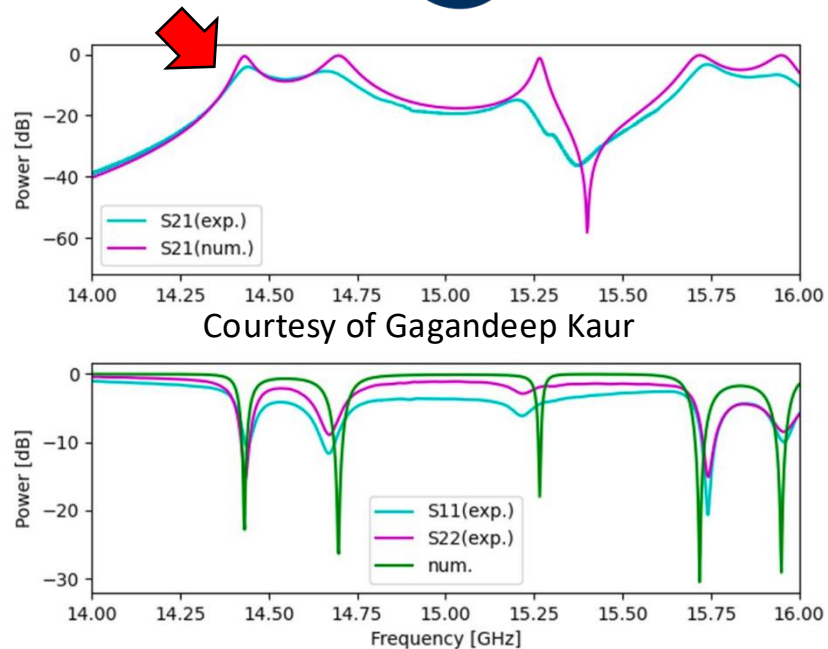

9T ϕ 20 cm

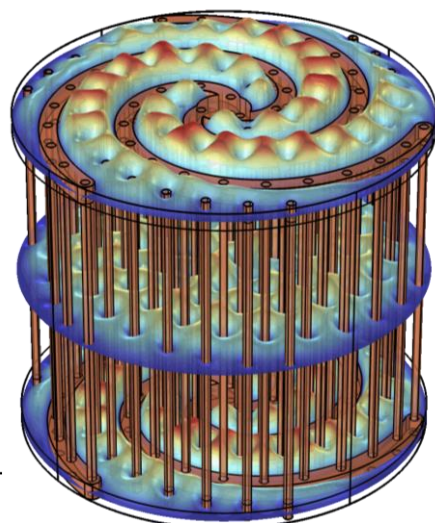
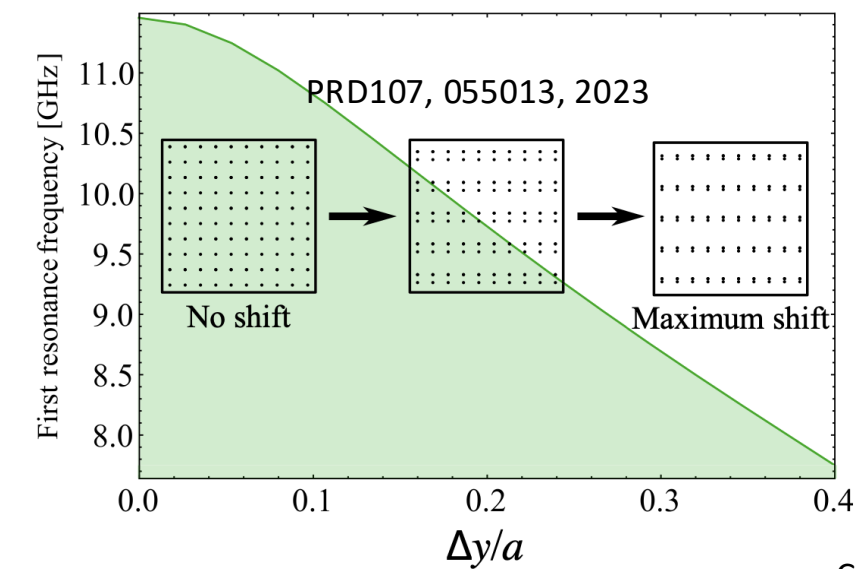
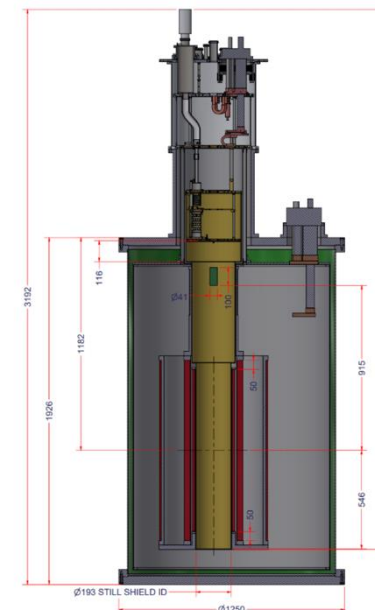

Courtesy of Alex Millar Jr.

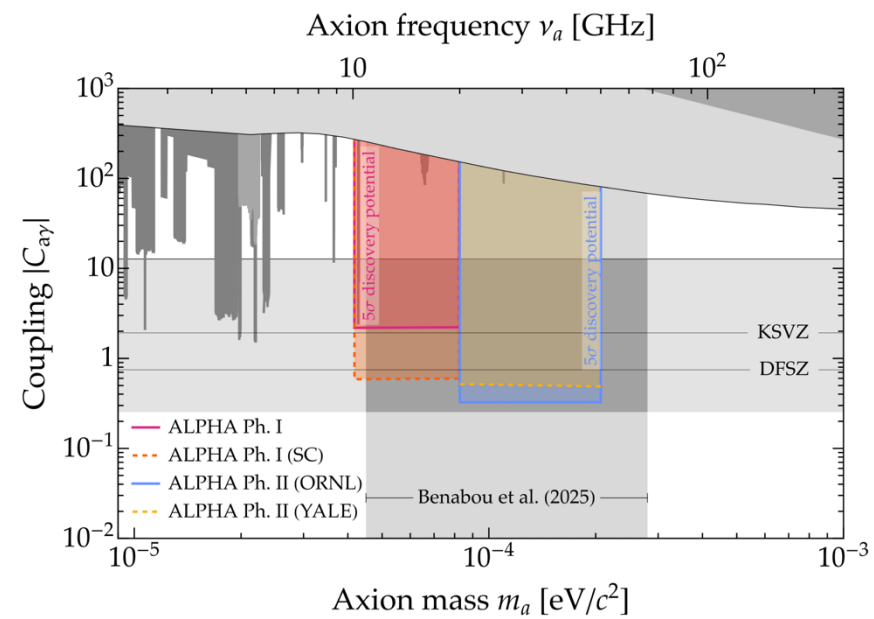
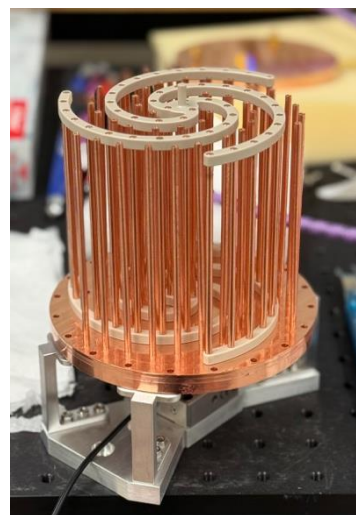

Outline

- We need new physics!
- DM axion as classical waves
- Axions at higher mass
- **Quantum sensing**
- Conclusion

Johnson Nyquist Thermal Noise

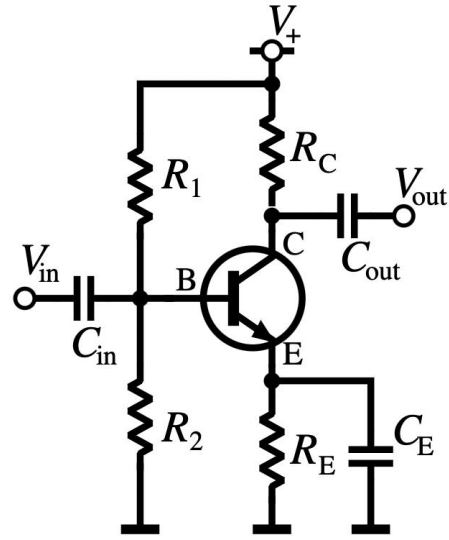
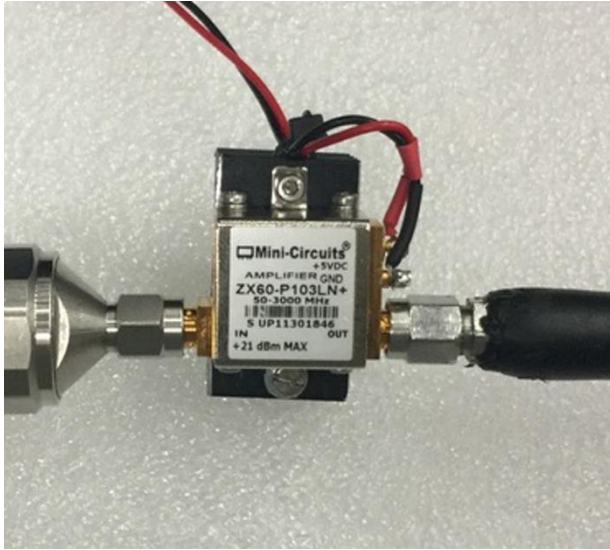

J. B. Johnson Phys Rev 32 97 (1928):
 Experimental discovery of the relation
 H. Nyquist Phys Rev 32 110 (1928):
 Thermodynamics + statistical mechanics
 of **bosonic** modes

Any conductor at temperature T

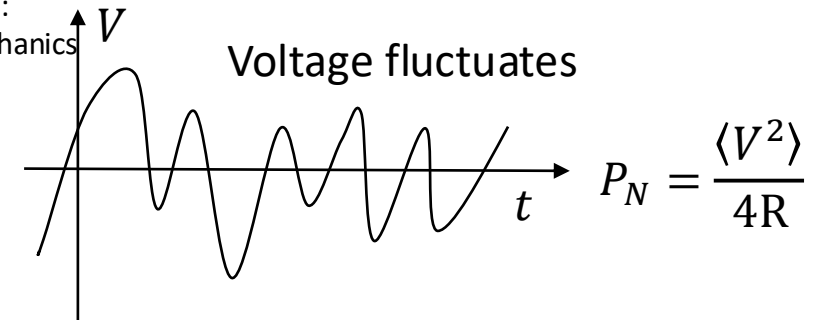
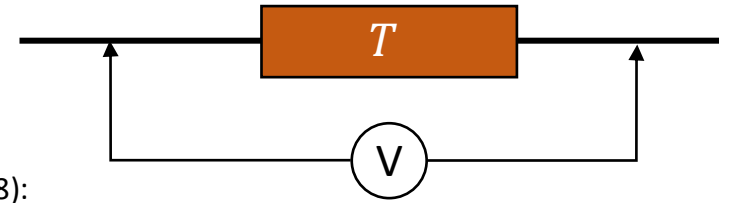

“Blackbody radiation” of electromagnetic waves inside a 1D conductor

$$\langle V^2 \rangle \Delta\nu \sim 4R \Delta\nu \frac{h\nu}{e^{h\nu/k_B T} - 1} \xrightarrow[\text{Rayleigh Jeans}]{h\nu \ll k_B T} 4R k_B T \Delta\nu$$

Noise PSD: $N = \frac{\langle V^2 \rangle}{4R \Delta\nu} \sim k_B T \text{ [W/Hz]}$

Average number of thermal photons

$$\bar{n} = \frac{1}{e^{h\nu/k_B T} - 1}$$

was derived by Planck via quantum statistics

Corresponding classical waves are incoherent chaos waves

Standard Quantum Limit from the Kennard inequality

$$[p, q] = \frac{i\hbar}{2} \rightarrow \langle \Delta p^2 \rangle \langle \Delta q^2 \rangle \geq |\langle [p, q] \rangle|^2 = \frac{\hbar^2}{4} \quad (\text{Kennard})$$

$$[p_i, q_i] = \frac{i\hbar}{2} = [p_f, q_f] \quad : \text{ before and after the amplifier chain}$$

$$q_f = Gq_i + q_g \quad p_f = Gp_i + p_g$$

$$[p_f, q_f] = [Gp_i, Gq_i] + [p_g, q_g] = \frac{iG^2\hbar}{2} + [p_g, q_g] = \frac{i\hbar}{2}$$

$$\rightarrow [p_g, q_g] = \frac{i(1 - G^2)\hbar}{2} \rightarrow \langle \Delta p_g^2 \rangle \langle \Delta q_g^2 \rangle \geq \frac{(G^2 - 1)\hbar^2}{4}$$

Amplifier uncertainty principle

$$P \geq \frac{1}{G^2} \left[\frac{G^2 h\nu}{2} + \frac{(G^2 - 1)h\nu}{2} \right] \xrightarrow{G \gg 1} 2 \times \frac{h\nu}{2} = h\nu$$

$P_{SQL} = h\nu$: standard quantum limit

$$\text{Ex) } h \times 1 \text{ GHz} = 6.6 \times 10^{-25} \text{ W/Hz}$$

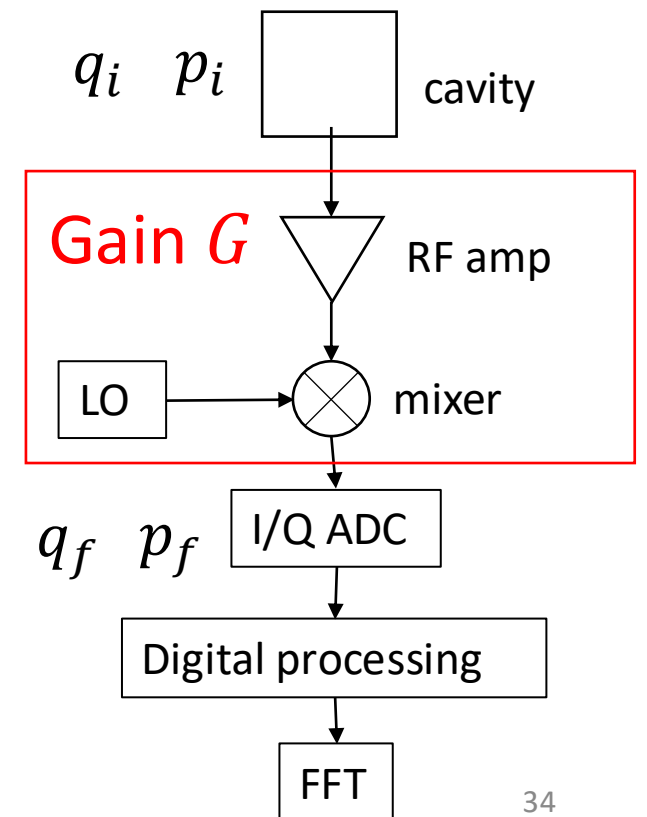
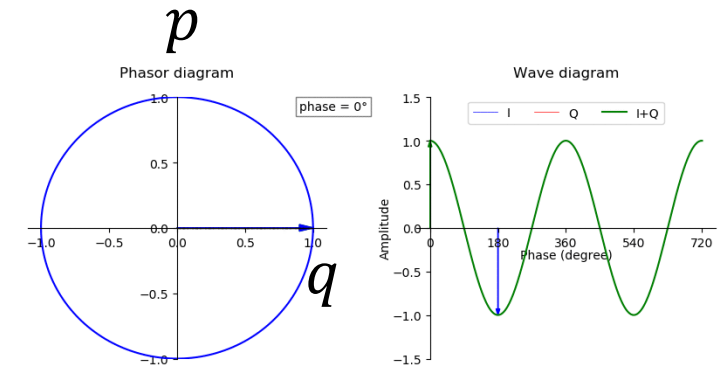

Single photon sensors can overcome SQL

Noise power of wave detection

$$P_l = h\nu(\bar{n} + 1) \sqrt{\frac{\Delta\nu}{t}} \propto \nu$$

Noise power of photon detection

$$P_{sp} = h\nu \sqrt{\frac{\eta\bar{n}Q_c}{2\pi\nu t}} \propto \sqrt{\nu}$$

$$\bar{n} = \frac{1}{e^{h\nu/k_B T} - 1}$$

Q_c : cavity quality factor

η : quantum efficiency of the sensor

S.K. Lamoreaux et al Phys Rev D 98 035020 (2013)

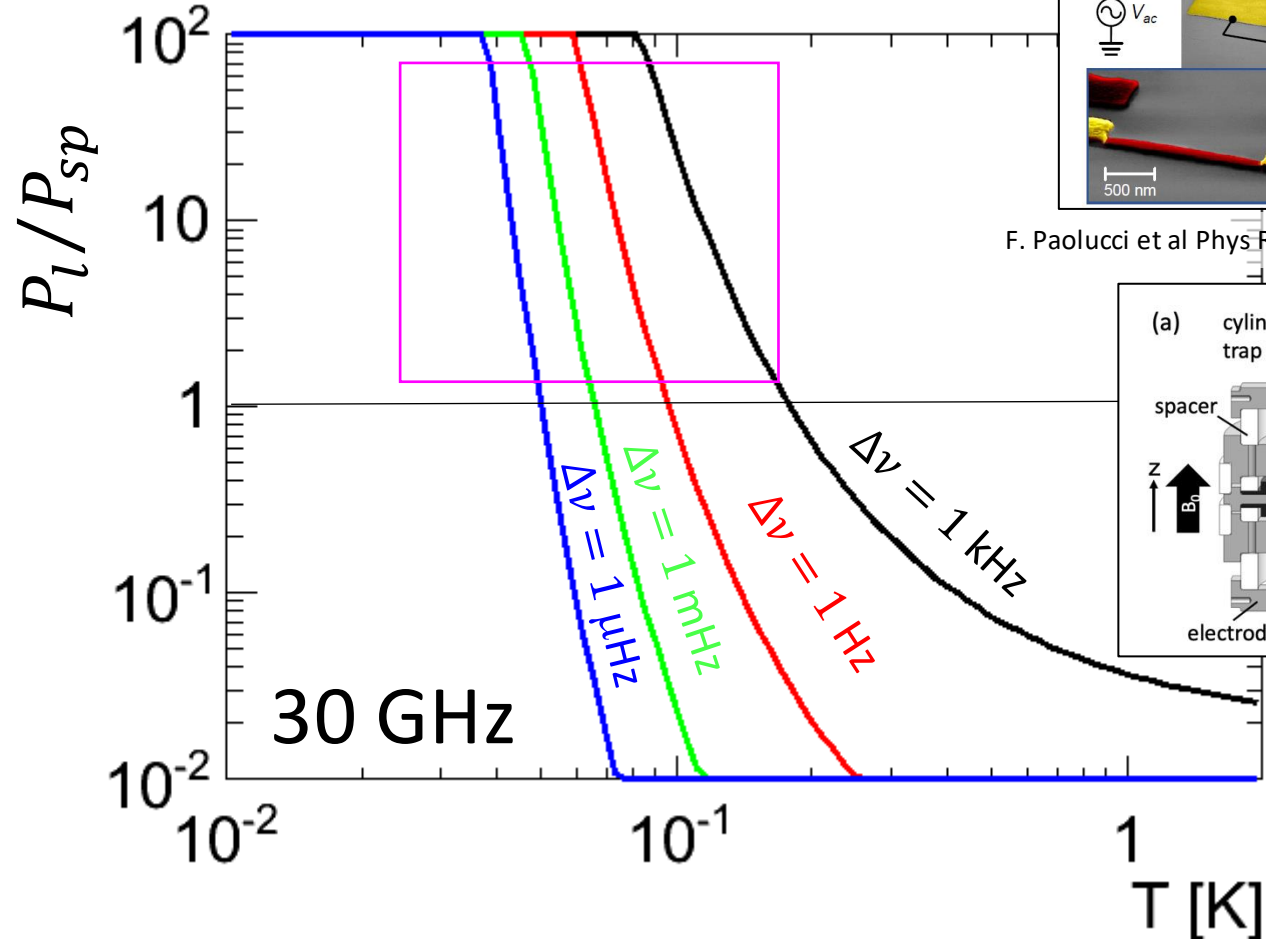

F. Paolucci et al Phys Rev Appl. 14 034055 (2020)

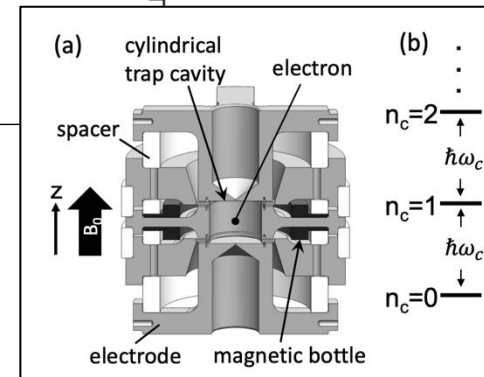

X. Fan et al, PRL129, 261801, 2022

Single photon sensors may be a solution in the future

→ Although one loses phase information, zero background at cold may be better

→ Lower noise in **higher frequency** → where is the cross-over? 10 GHz? 100 GHz??

Question: classical \rightarrow quantum



$$\epsilon \nabla \cdot \mathbf{E} = \rho - g_{a\gamma} \mathbf{B}_e \cdot \nabla a,$$

$$\nabla \times \mathbf{H} - \dot{\mathbf{E}} = \mathbf{J} + g_{a\gamma} \mathbf{B}_e \dot{a},$$

$$\ddot{a} - \nabla^2 a + m_a^2 a = g_{a\gamma} \mathbf{E} \cdot \mathbf{B}_e,$$

What is the quantum statistical distribution of detected photons?

\rightarrow Goal: Monte Carlo

- Can we obtain quantum statistical distribution without assuming quantum nature in the source?
- Can we assume a Poisson distribution?

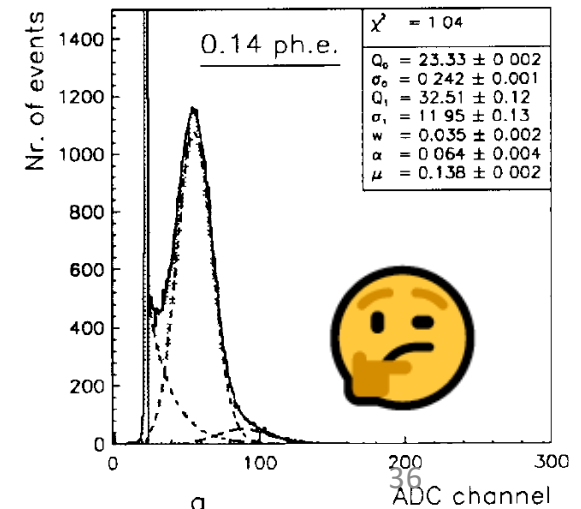

Glauber's theorem: classical \rightarrow quantum

PHYSICAL REVIEW

VOLUME 131, NUMBER 6

15 SEPTEMBER 1963

Coherent and Incoherent States of the Radiation Field*

ROY J. GLAUBER

Lyman Laboratory of Physics, Harvard University, Cambridge, Massachusetts

(Received 29 April 1963)

$$H_1(t) = -\frac{1}{c} \int \mathbf{j}(\mathbf{r}, t) \cdot \mathbf{A}(\mathbf{r}, t) d\mathbf{r}. \quad (9.16)$$

The introduction of an explicitly time-dependent interaction of this type means that the state vector for the field, $| \rangle$, which previously was fixed (corresponding to the Heisenberg picture) will begin to change with time in accordance with the Schrödinger equation

$$i\hbar \frac{\partial}{\partial t} | \rangle = H_1(t) | \rangle, \quad (9.17)$$

which is the one appropriate to the interaction representation. The solution of this equation is easily found.²⁰ If we assume that the initial state of the field at time $t = -\infty$ is one empty of all photons, then the state of the field at time t may be written in the form

$$|t\rangle = \exp \left\{ \frac{i}{\hbar c} \int_{-\infty}^t dt' \int \mathbf{j}(\mathbf{r}, t') \cdot \mathbf{A}(\mathbf{r}, t') d\mathbf{r} + i\varphi(t) \right\} | \text{vac} \rangle. \quad (9.18)$$

$$D_k(\beta_k) = \exp[\beta_k \alpha_k^\dagger - \beta_k^* \alpha_k]. \quad (9.19)$$

Then it is clear from the expansion (2.10) for the vector potential that we may write

$$\exp \left\{ \frac{i}{\hbar c} \int_{-\infty}^t dt' \int \mathbf{j}(\mathbf{r}, t') \cdot \mathbf{A}(\mathbf{r}, t') d\mathbf{r} \right\} = \prod_k D_k[\alpha_k(t)], \quad (9.20)$$

where the time-dependent amplitudes $\alpha_k(t)$ are given by

$$\alpha_k(t) = \frac{i}{(2\hbar\omega)^{1/2}} \int_{-\infty}^t dt' \int d\mathbf{r} \mathbf{u}_k^*(\mathbf{r}) \cdot \mathbf{j}(\mathbf{r}, t') e^{i\omega t'}. \quad (9.21)$$

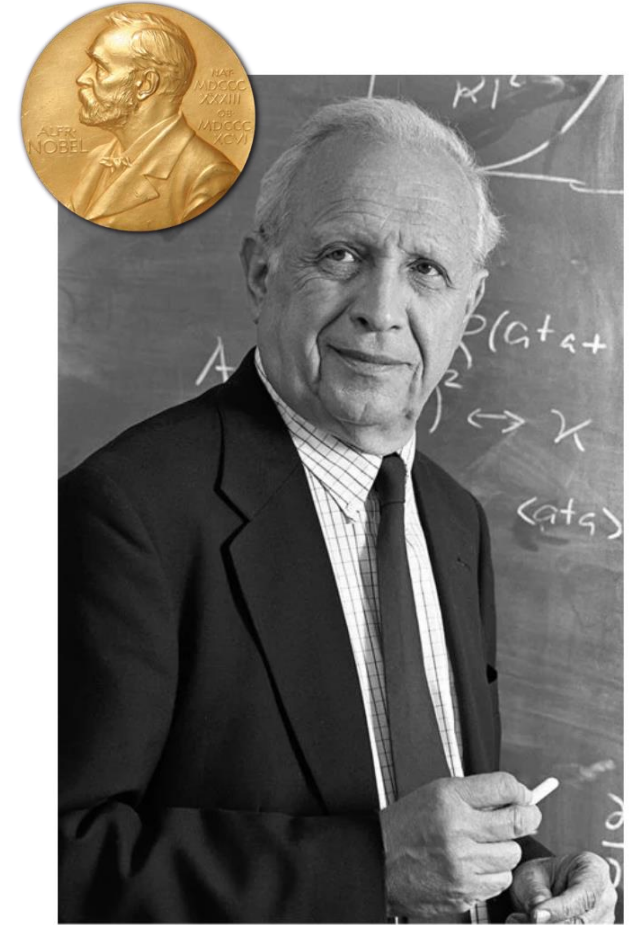
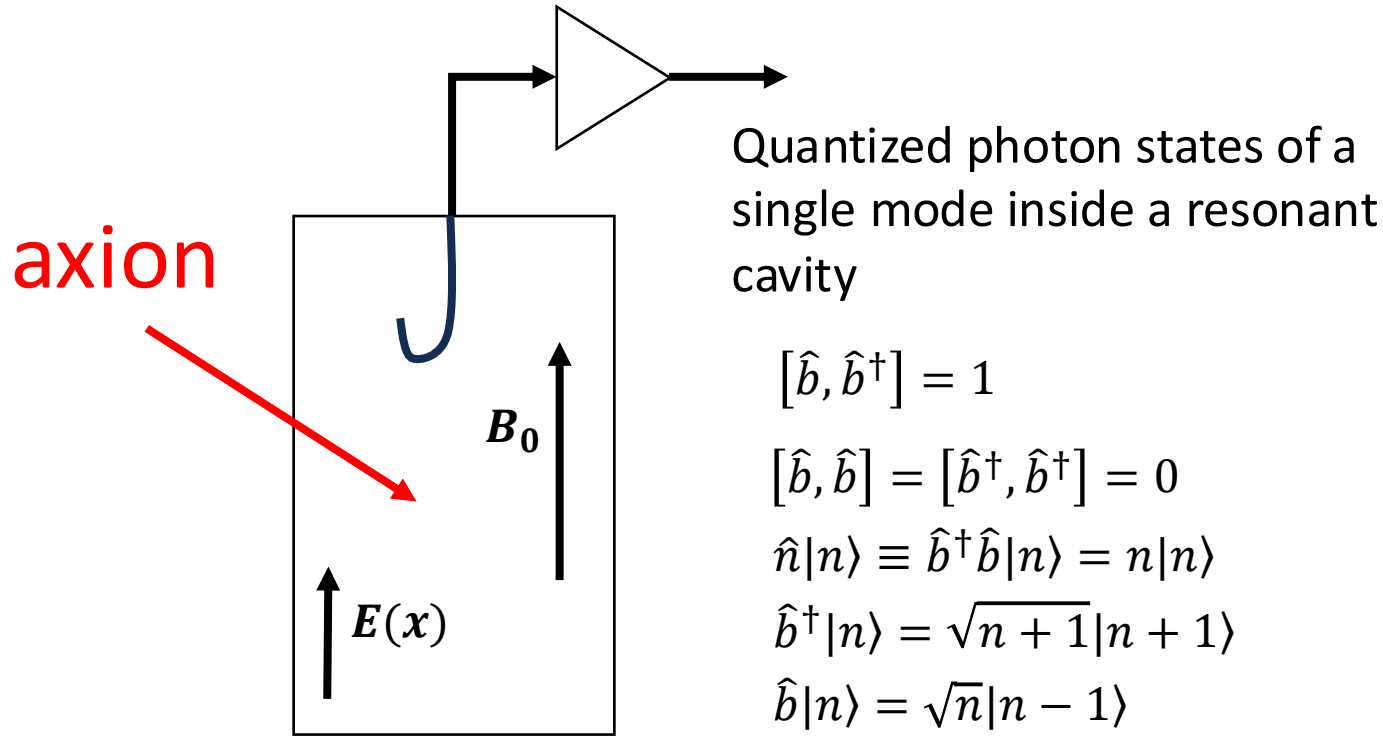

Photo: J.Reed

Classical current generates quantized photons in a quantum coherent state
 \rightarrow Let's apply this to classical axions

Any classical axion generates photons in a quantum coherent state



Quantum state of photons from axions

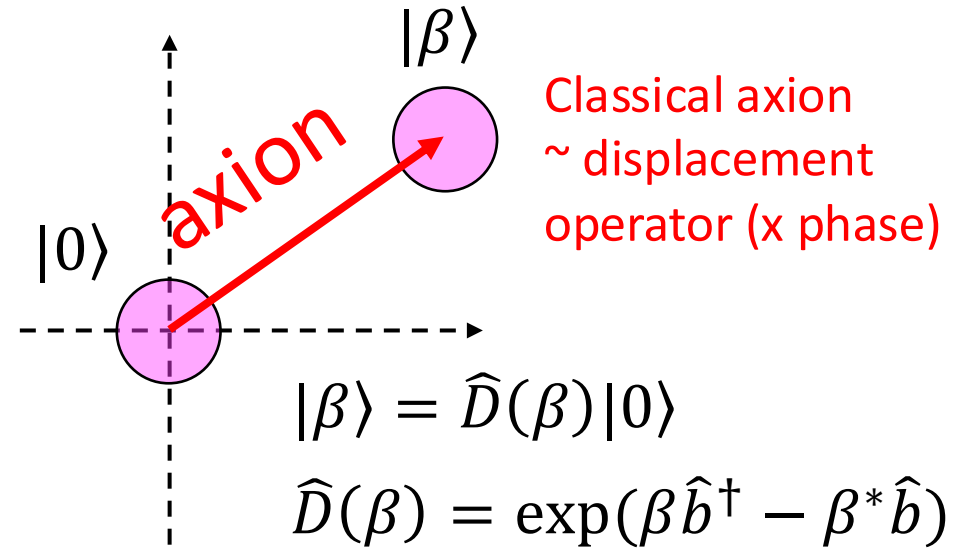

Only linear operators

$$\hat{H} = \underbrace{\hbar\omega \left(\hat{b}^\dagger \hat{b} + \frac{1}{2} \right)}_{\hat{H}_0} + \underbrace{\hbar[f(t)\hat{b}^\dagger + f^*(t)\hat{b}]}_{\hat{V}_I}$$

$$f(t) = g_{a\gamma\gamma} \underbrace{a(t)}_{\text{Any classical axion field}} \int (\mathbf{E}(x) \cdot \mathbf{B}_0) d^3x$$

Exact solution without perturbation

$$\begin{cases} |\psi(t)\rangle = \exp(-iC_1(t)) \hat{D}(\beta(t)) \exp(-iH_0 t/\hbar) |\psi(0)\rangle \\ \beta(t) = C_2(t) \exp(-i\omega t) \\ C_1(t) = -\frac{i}{2} \int_0^t dt' f^*(t') \exp(i\omega t') \int_0^{t'} dt'' f(t'') \exp(i\omega t'') \\ C_2(t) = \int_0^t dt' f(t') \exp(i\omega t') \end{cases}$$

Derived by Ayuki Kamada U Warsaw

Der stetige Übergang von der Mikro- zur Makromechanik.

Von E. SCHRÖDINGER, Zürich.

$$\frac{m}{2} \left(\frac{dq}{dt} \right)^2 + 2 \pi^2 \nu_0^2 m q^2$$

$$\left. \begin{aligned} \psi_n &= e^{-\frac{x^2}{2}} H_n(x) e^{2 \pi i \nu_n t} \\ \left(\nu_n &= \frac{2n+1}{2} \nu_0; n = 0, 1, 2, 3, \dots \right) \end{aligned} \right\} (3)$$

Die H_n sind die nach HERMITE benannten

$$\begin{aligned} \psi &= \sum_{n=0}^{\infty} \left(\frac{A}{2} \right)^n \frac{\psi_n}{n!} \\ &= e^{\pi i \nu_0 t} \sum_{n=0}^{\infty} \left(\frac{A}{2} e^{2 \pi i \nu_0 t} \right)^n \frac{1}{n!} e^{-\frac{x^2}{2}} H_n(x). \end{aligned}$$

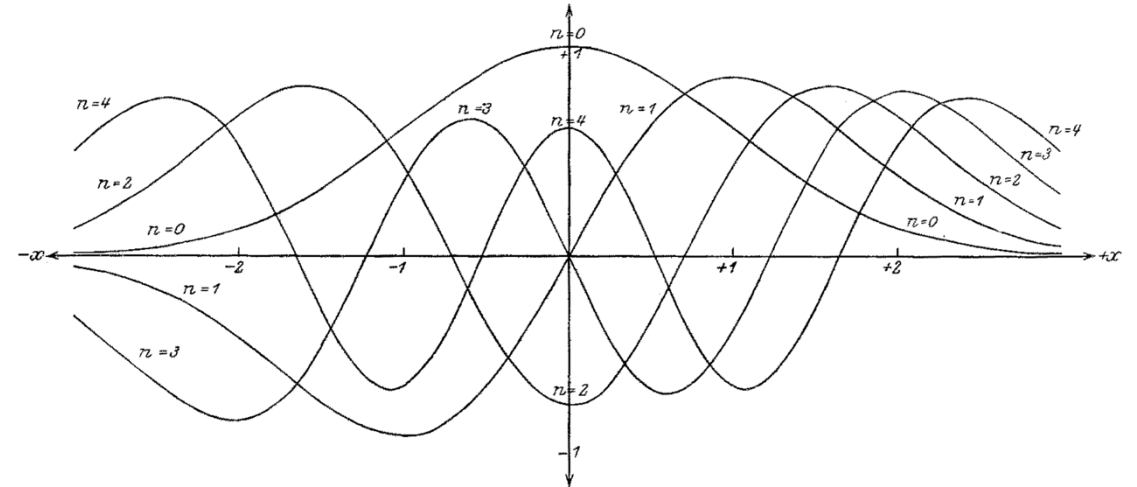

$$\psi = e^{\frac{A^2}{4} - \frac{1}{2} (x - A \cos 2 \pi \nu_0 t)^2} \cdot \cos \left[\pi \nu_0 t + (A \sin 2 \pi \nu_0 t) \cdot \left(x - \frac{A}{2} \cos 2 \pi \nu_0 t \right) \right]$$

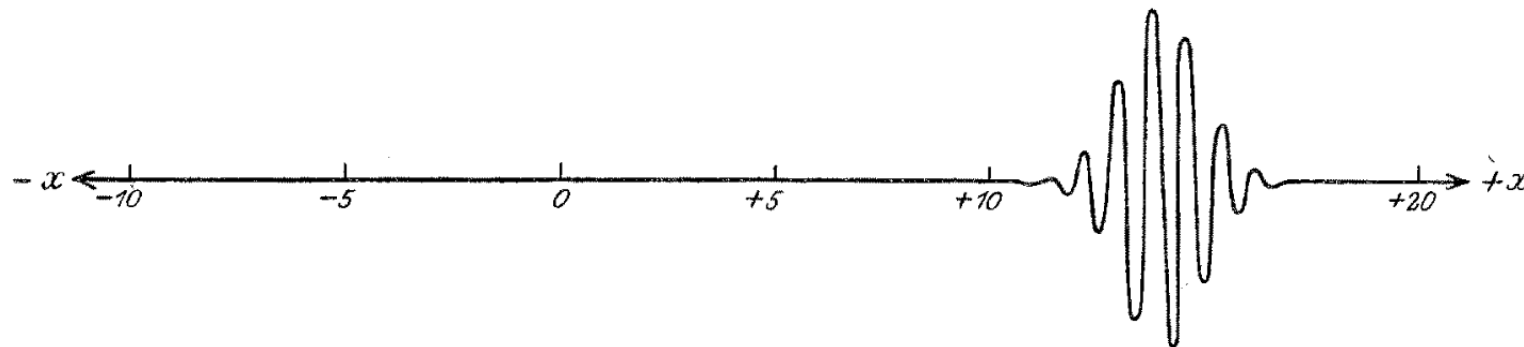

Schrödinger, E. (1926). "Der stetige Übergang von der Mikro- zur Makromechanik". Die Naturwissenschaften 14 (28)

Quantum coherent state: Schrödinger's wave packet

$$\Psi(x_1) = \frac{1}{\sqrt{2\pi}} e^{-(x_1 - \alpha \cos \omega t)^2}$$

$$\alpha \Psi(x_1) = \left[x_1 + \frac{1}{2} \frac{d}{dx_1} \right] \Psi(x_1)$$

α : eigenvalue of annihilation operator

$$\hat{a} \equiv \hat{x}_1 + i\hat{x}_2$$

$$a|\alpha\rangle = \alpha|\alpha\rangle$$

Hints for derivation

$$\Psi(x_1) \equiv \langle x_1 | \alpha \rangle$$

$$\langle x_1 | \hat{x}_1 | x_1 \rangle = x_1$$

$$[\hat{x}_1, \hat{x}_2] = \frac{i}{2} \rightarrow \langle x_1 | \hat{x}_2 | x_1 \rangle \equiv \frac{1}{2i} \frac{d}{dx_1}$$

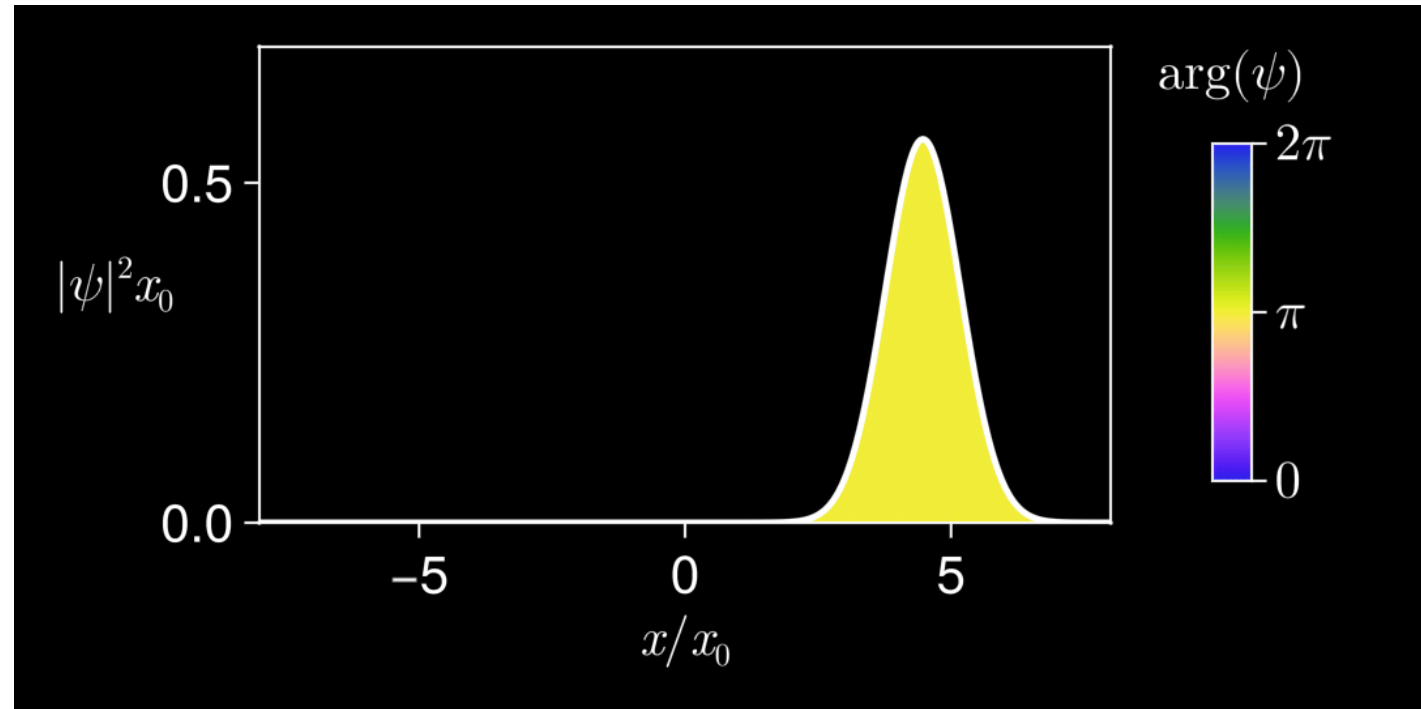

By Ashton Bradley Aspir8 (talk) - Own work, CC BY-SA 4.0, <https://commons.wikimedia.org/w/index.php?curid=149671045>

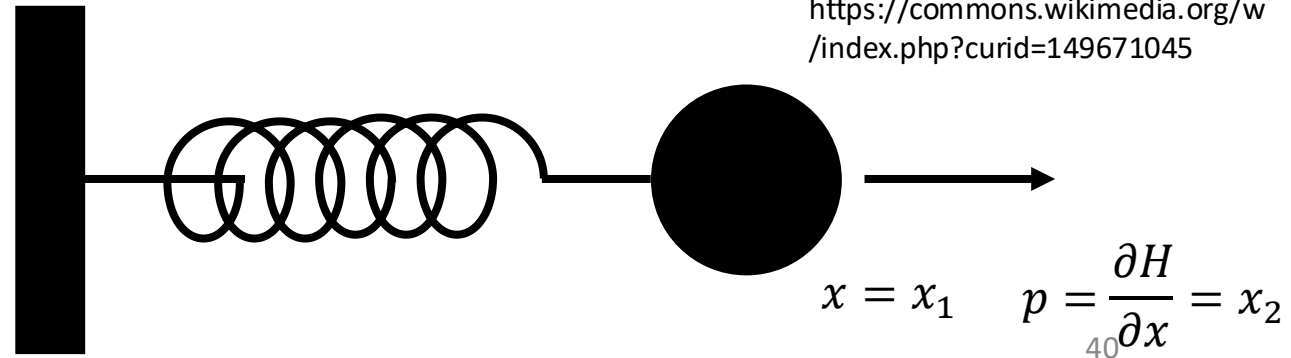

Modern representation of wave packet: coherent state

$$|\alpha\rangle = e^{-|\alpha|^2/2} \sum_{n=0}^{\infty} \frac{\alpha^n}{\sqrt{n!}} |n\rangle$$

Displacement operator

$$D(\alpha) \equiv \exp(\alpha \hat{a}^\dagger - \alpha^* \hat{a})$$

$$|\alpha\rangle = D(\alpha)|0\rangle$$

Electric field operator

$$\hat{\mathcal{E}}(\mathbf{r}, t) = i \sqrt{\frac{\hbar\omega}{2\epsilon_0 V}} [\hat{a} e^{-i(\omega t - \mathbf{k}\cdot\mathbf{r})} - \hat{a}^\dagger e^{i(\omega t - \mathbf{k}\cdot\mathbf{r})}]$$

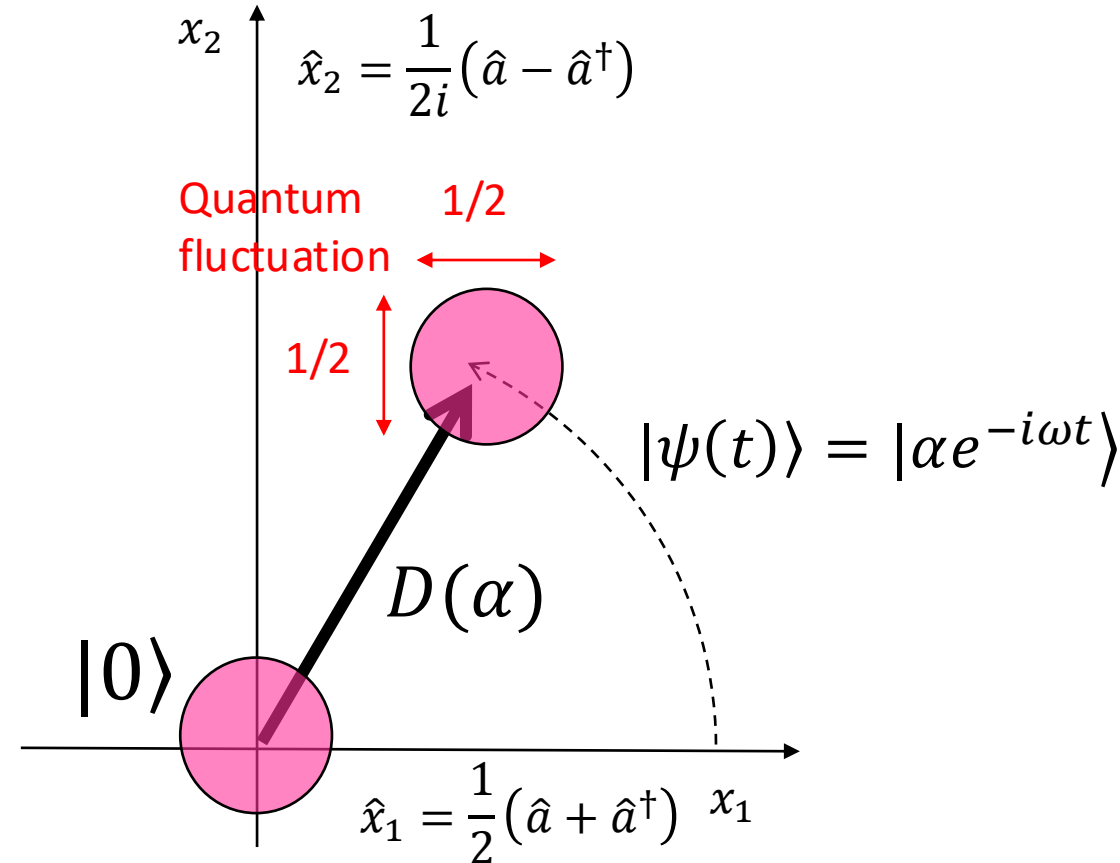

$$\left\{ \begin{array}{l} E \equiv \langle \alpha | \hat{\mathcal{E}}(\mathbf{r}, t) | \alpha \rangle = i \sqrt{\frac{\hbar\omega}{2\epsilon_0 V}} [\alpha e^{-i(\omega t - \mathbf{k}\cdot\mathbf{r})} - \alpha^* e^{i(\omega t - \mathbf{k}\cdot\mathbf{r})}] \quad : \text{Plane wave solution of Maxwell equation} \\ P(n) = |\langle n | \alpha \rangle|^2 = \frac{(|\alpha|^2)^n}{n!} e^{-|\alpha|^2} \quad : \text{Poisson distribution} \end{array} \right. \rightarrow \text{Axion via amplifier}$$

→ Axion via photon counting

Outline

- We need new physics!
- DM axion as classical waves
- Axions at higher mass
- Quantum sensing
- **Conclusion**

Conclusion

- We need new physics!
 - SM does not include DMs: WIMPs or others?
 - RF technology is the key for the next accelerator: wakefield in FCCee \rightarrow 2HDM $\tan \beta$
 - RF will be also useful for direct detection of DMs: axion DM $\rightarrow m_a$
- DM axion as classical waves
 - Axion solves the strong CP problem in SM and can be a light DM candidate
 - Light dark matter \rightarrow long de Broglie wavelength \rightarrow classical waves
 - Axion DM \rightarrow Maxwell equation \rightarrow classical microwaves
- Axions at higher mass
 - Higher mass axions are motivated if inflation scale is higher than PQ
 - Momentum mismatch to microwaves \rightarrow dish antenna, dielectric, wire metamaterial
- Quantum sensing
 - Classical microwave sensing reaches SQL \rightarrow photon counting
 - Classical axions generate microwave photons in a quantum coherent state

More pedagogical lectures of mine

- 90 min x 3 lectures on axions in Nagoya University
 - <https://indico.kmi.nagoya-u.ac.jp/event/15/overview>
- 1-week lectures + hands-on about RF for axions in Hamburg University
 - <https://indico.desy.de/event/50207/>
- CERN Summer Student Lecture about superconducting cavities
 - <https://indico.cern.ch/event/1508891/>
- Introduction to accelerators technology at Université Paris Saclay
 - <https://indico.ijclab.in2p3.fr/event/11923/>
- Textbooks (we do not have established textbook for axions ☹):

